

# Varispeed-520B

# INSTRUCTIONS

STATIC DC ADJUSTABLE SPEED DRIVES

TYPE CDMR-L5 FOR NON-REVERSING DRIVES

TYPE CDMR-D5 FOR REVERSING DRIVES

---

Upon receipt of the product and prior to initial operation, read these instructions thoroughly, and retain for future reference.

---



The Varispeed-520B is a medium capacity Leonard Drive thyristor conversion unit designed for use with high class variable speed drives.

This manual explains basic correct operating procedures for the Varispeed-520B. For operations other than those covered here, refer to separate instruction manuals for guidance.

Read this manual thoroughly before operation, and always follow correct operation procedures. Keep this manual in a safe place with easy reference for maintenance, inspection and other problems.

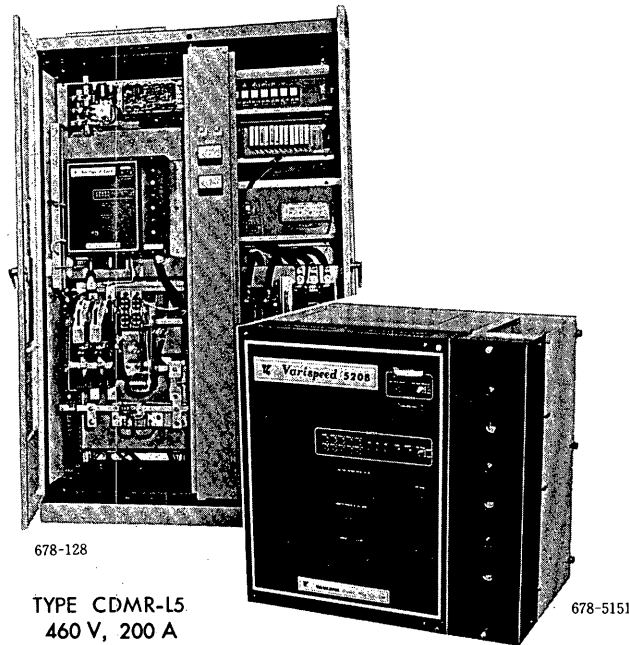

## General Precautions

- Some drawings in this manual are shown with the protective cover or shields removed, in order to describe detail with more clarity. Make sure all covers and shields are replaced before operating this product.
- Any illustrations, photographs, or examples used in this manual are provided as examples only and may not apply to all products to which this manual is applicable.
- This manual may be modified when necessary because of improvement of the product, modification, or changes in specifications.  
Such modifications are denoted by a revised manual No.
- Contact your YASKAWA representative listed on the back of this manual to order a new manual whenever this manual is damaged or lost.  
Please provide the document number listed on the front cover of this manual when ordering.
- Contact your YASKAWA representative listed on the back of this manual to order new nameplates whenever a nameplate becomes worn or damaged.
- YASKAWA is not responsible for any modification of the product made by the user, since that will void your guarantee.

# NOTES FOR SAFE OPERATION

Read this manual thoroughly before use of Varispeed-520B. In this manual, NOTES FOR SAFE OPERATION are classified as "WARNING" and "CAUTION".



: Indicates a potentially hazardous situation which, if not avoided, could result in death or serious injury to personnel.



: Indicates a potentially hazardous situation which, if not avoided, may result in minor or moderate injury to personnel and damage to equipment. It may also be used to alert against unsafe practices.

Even items described in  **CAUTION** may result in a vital accident in some situations. In either case, follow these important notes.

## INSTALLATION

 <b>CAUTION</b>
<ul style="list-style-type: none"><li>• The installation environment must meet the environmental conditions given in the product catalog and manuals. Failure to observe this caution may result in electric shock, fire, or faulty operation.</li><li>• Install products correctly according to the instructions. Improper installation may result in accidents or malfunctions.</li><li>• Lift the VS-520B by the base. Otherwise, the main unit may be dropped, causing damage to the unit.</li></ul>

## WIRING

 <b>WARNING</b>
<ul style="list-style-type: none"><li>• Wiring must be performed by qualified personnel. Mistakes in wiring can cause electric shock or a fire.</li></ul>

 <b>CAUTION</b>
<ul style="list-style-type: none"><li>• Main circuit external terminals use bar type connections. Cover live connections when being installed. Failure to observe this caution may result in electric shock.</li></ul>

## TEST OPERATION



### WARNING

- Do not touch terminals under current conditions.  
There is danger of electric shock.
- Never touch the thyristor cooling fin during or immediately after operation.  
Failure to observe this warning can result in a burn, personal injury, or electric shock.



### CAUTION

- The bottom part of the Varispeed-520B is equipped with a cooling fan. Never touch the fan during operation.  
Failure to observe this caution can result in personal injury.

## MAINTENANCE



### CAUTION

- Do not disassemble or assemble the VS-520B other than as described in this manual.  
Electric shock or faulty operation may occur.
- Turn off the power during parts replacement.  
Failure to observe this caution may result in electric shock or faulty operation.
- Be sure the model, rating and specifications match when replacing parts. Replacement should be carried out within the time specified for each part.  
Failure to observe this caution can result in burnout or faulty operation.

## DISPOSAL



### CAUTION

When disposing of this unit, handle as general industrial waste.

---

## CONTENTS

NOTES FOR SAFE OPERATION	
RATINGS AND SPECIFICATIONS .....	2
WIRING .....	6
TEST OPERATION .....	6
ADJUSTMENT .....	10
MAINTENANCE .....	15
SPARE PARTS .....	21
DIAGRAMS .....	22
APPENDIX .....	26

---

### IMPORTANT NOTICE

- Never make dielectric voltage test because of electronic packaged unit.
- If insulation resistance test is required, make it with special care, refer to the page 5.
- Do not remove or insert front panel of the unit and fuse cover while power is applied to the equipment.
- Do not tamper with check terminals and switches on front panel while in operation.

# RATINGS AND SPECIFICATIONS

**RATINGS** (Refer to Tables 1 and 2.)

Table 1 VS-520B Type CDMR-L5 Non-Reversing Drives

Power Supply	Cooling Method	Nominal Rated Voltage V	Nominal Rated Current* A	Code No. (Dwg. No.)
3 Phase 170 - 255 V 50/60 Hz	—	230	80	EPJ00422X
	Fan	230	200	EPJ00423X
			300	EPJ00425X
			500	EPJ00427X
3 Phase 340 - 510 V 50/60 Hz	Fan	460	80	EPJ00446X
			200	EPJ00424X
			300	EPJ00426X
			500	EPJ00428X
			800	EPJ00429X
			900	EPJ00430X
			1500	EPJ00431X
			1650	EPJ00444X

Table 2 VS-520B Type CDMR-D5 Reversing Drives

Power Supply	Cooling Method	Nominal Rated Voltage V	Nominal Rated Current* A	Code No. (Dwg. No.)
3 Phase 170 - 255 V 50/60 Hz	—	230	80	EPJ00432X
	Fan	230	200	EPJ00433X
			300	EPJ00435X
			500	EPJ00437X
3 Phase 340 - 510 V 50/60 Hz	Fan	460	80	EPJ00447X
			200	EPJ00434X
			300	EPJ00436X
			500	EPJ00438X
			800	EPJ00439X
			900	EPJ00440X
			1500	EPJ00441X
			1650	EPJ00443X

\* The nominal rated currents are defined as class A described in JEC 188 (JEC--Standard of Japanese Electrotechnical Committee). For various rated currents according to duty class, see "Appendix"

Asymmetrical inverse-parallel thyristor convertors and available upon request for rated currents 800A or above.

• For antiparallel connected reversing drive with circulating-current control and reversing drive with contactors, refer to separate instructions.

## TYPE DESIGNATION OF VS-520B

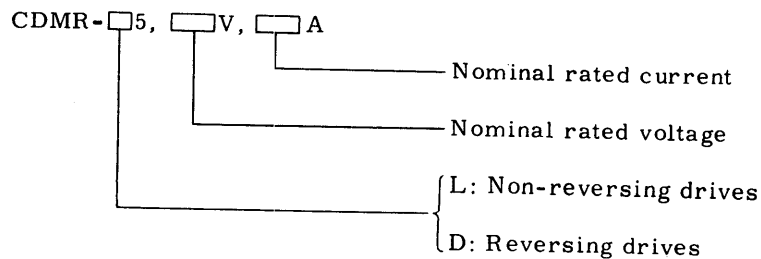

# BLOCK DIAGRAMS

CYS-520B drives include **A** Control Board and **B** Thyristor Module, see Figs. 1 and 2.  
 Module:

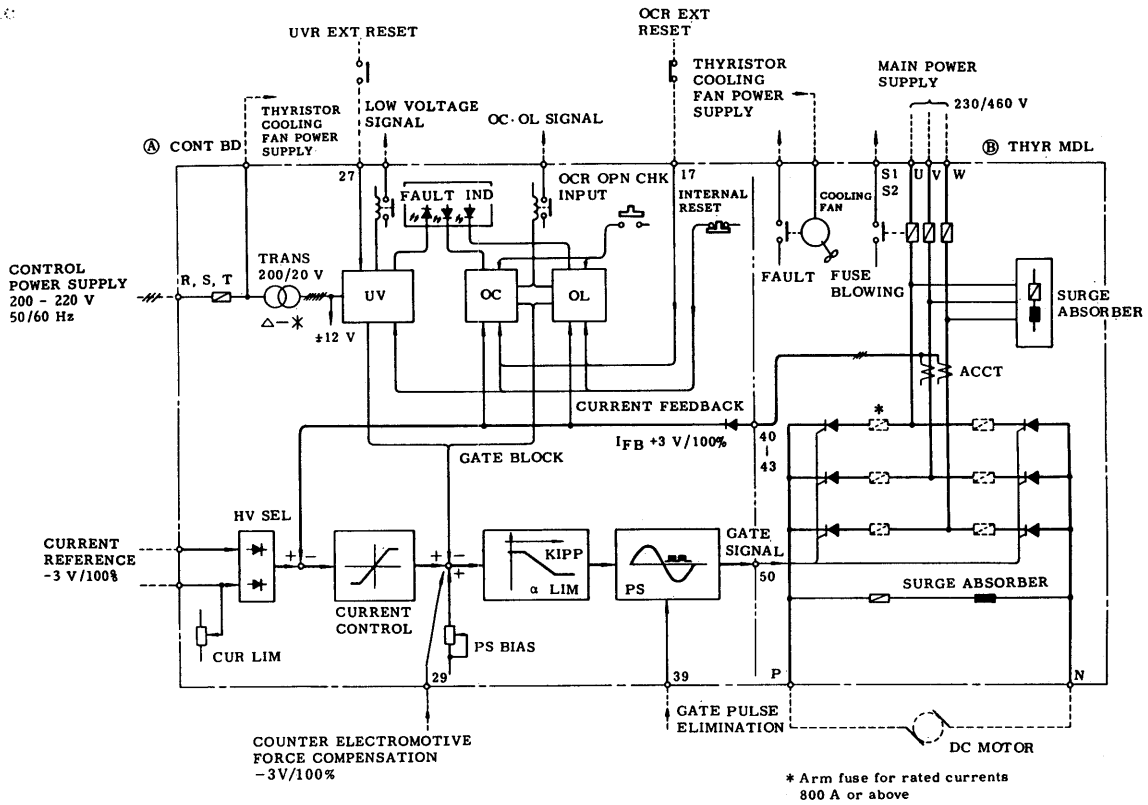
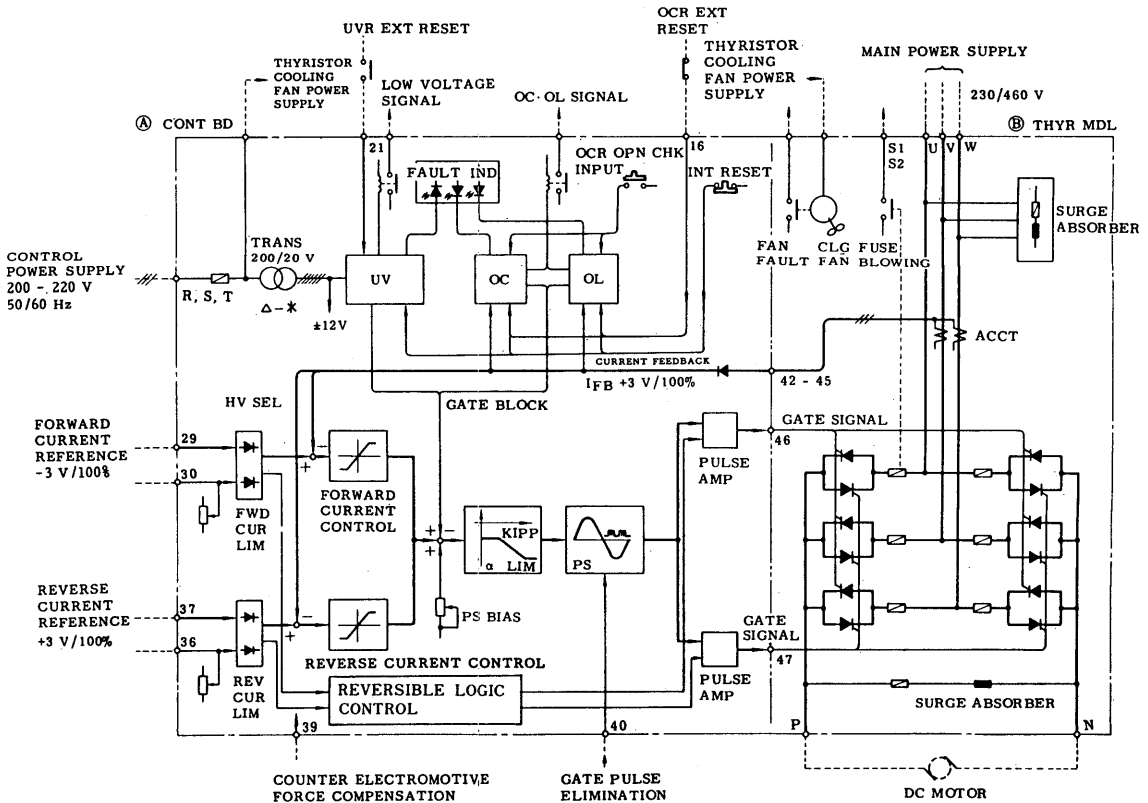

Fig. 1 Type CDMR-L5 Single Converter



Construction of VS-520B units corresponding with their control methods and nominal ratings are shown in Figs. 3 to 5.

Parts list is given in Table 12.

Fig. 2 Type CDMR-D5 Double Converter

**TYPE CDMR-L5, 230/460 V, 80 - 500 A**

Control Board Provides with Hinge and Thyristor Module Has Semi-Plug in Construction.

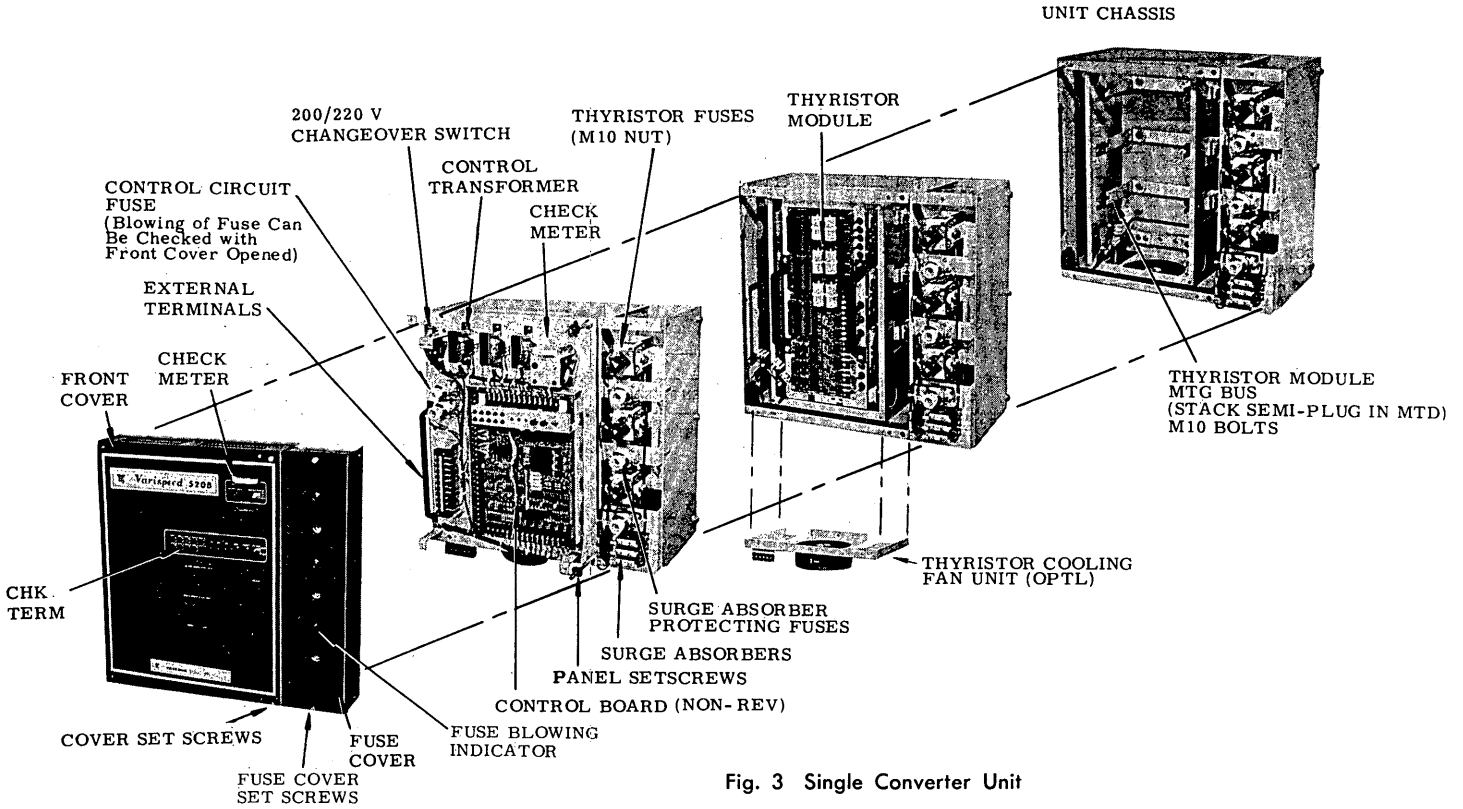

Fig. 3 Single Converter Unit

**TYPE CDMR-D5, 230/460 V, 80 - 500 A**

Control Board Provides with Hinge and Thyristor Module Has Semi-Plug in Construction.

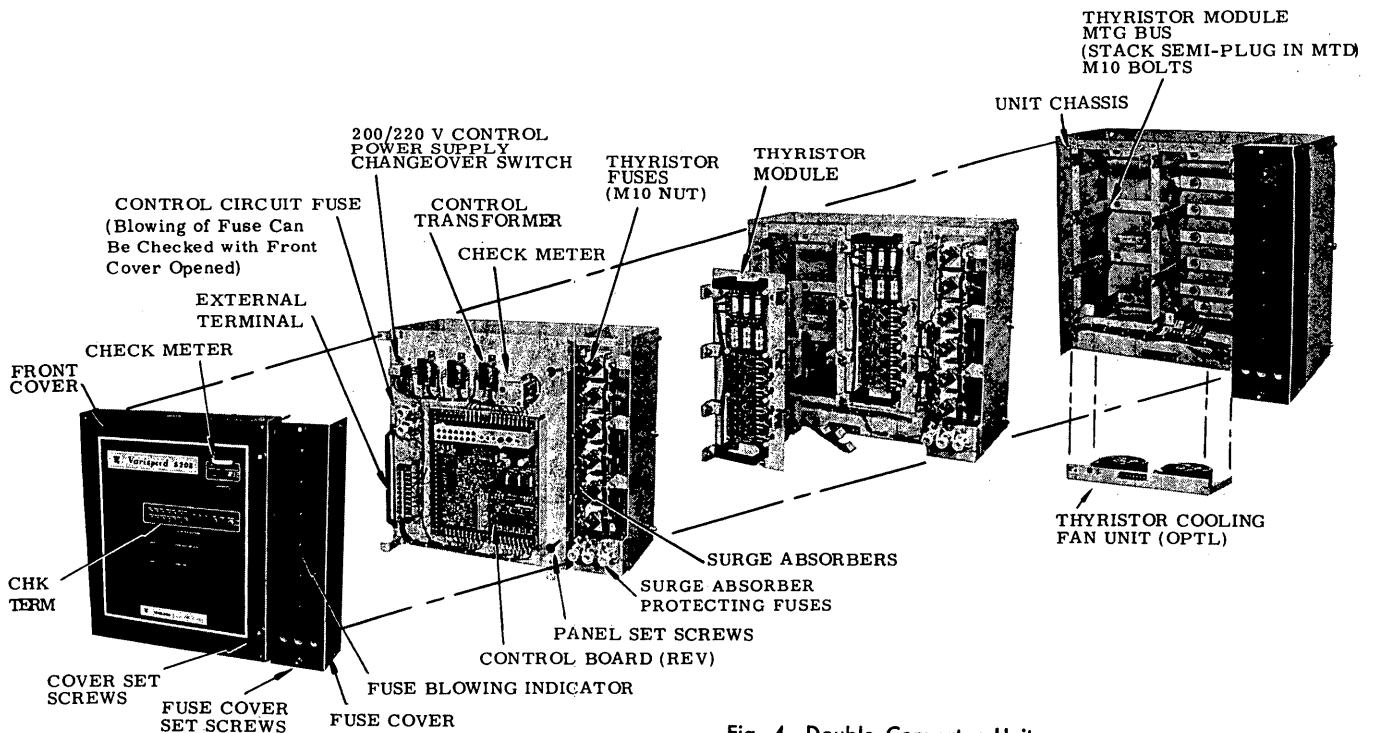

Fig. 4 Double Converter Unit



## TYPE CDMR-D5, 460V, 800-900A

Control Board Provides with Hinge and Thyristor Module Has Semi-Plug in Construction.

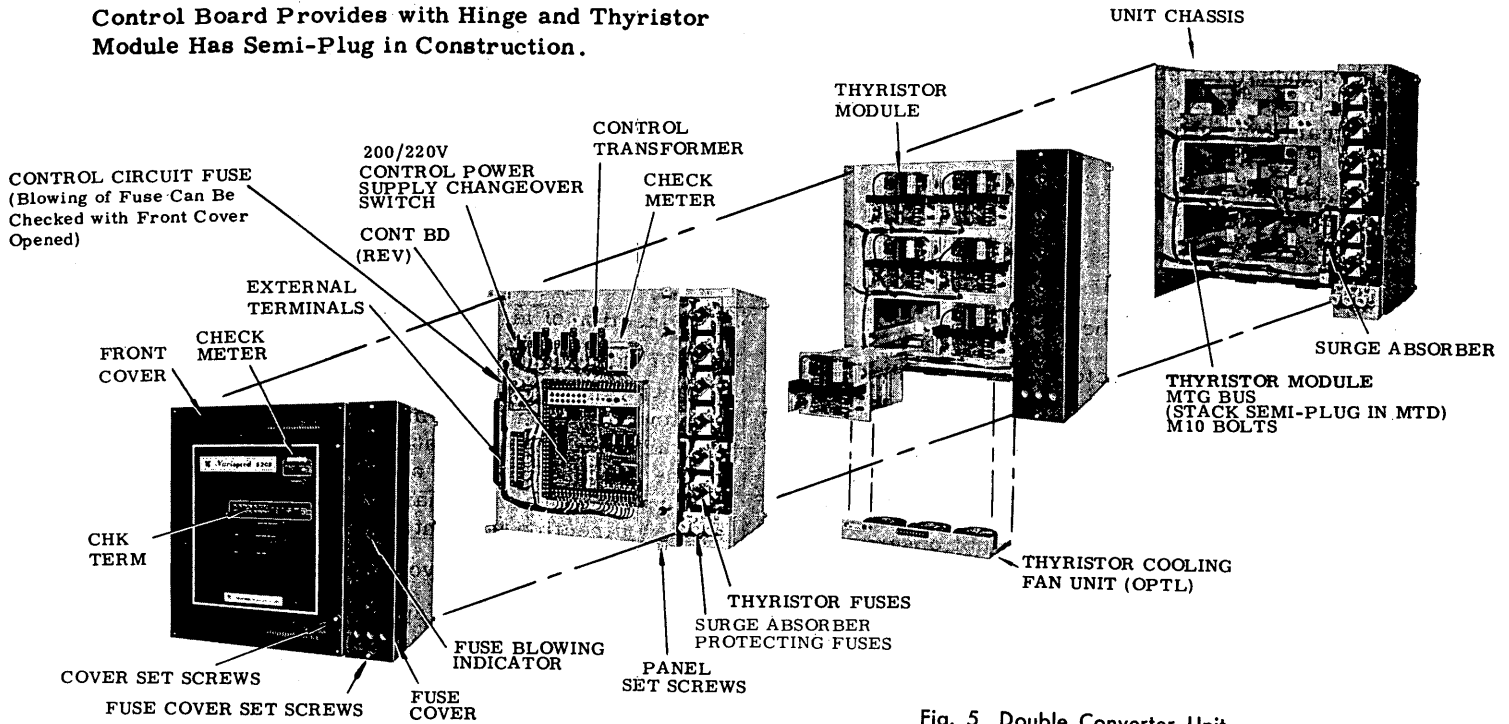

Fig. 5 Double Converter Unit

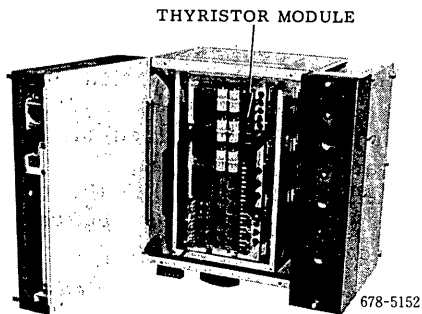

Fig. 6 Converter Unit with Front Cover Opened

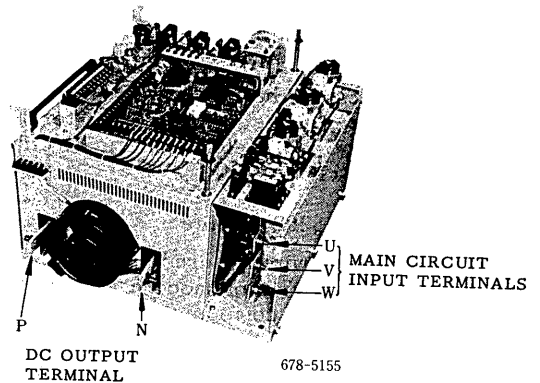

Fig. 7 Main Circuit Input Terminals and DC Output Terminals Shortcircuited

### CAUTION

When any of the VS-520B components is required with insulation resistance tests, follow the procedures below.

#### < DO NOT APPLY WITHSTAND VOLTAGE TESTS TO ANY OF THE COMPONENTS >

- Open the front cover by loosening the two cover set screws. See Fig. 6.
- With all the gate wires on the thyristor module (screwed terminals with G-K indications) disconnected, and the gate leads and the cathode leads shorted, wrap the exposed parts with insulating tapes to separate the main circuit from the control circuit. **DO NOT APPLY INSULATION RESISTANCE TESTS TO THE CONTROL CIRCUIT.**
- Short circuit all the main circuit terminals on the thyristor module with clips. Now, no voltage difference can be measured across the main AC input terminals (U, V, W) and the DC output terminals (P, N). See Fig. 7.

Measure the resistance between the main circuit and the ground with a 500 V megger. The normal resistance is 2 MΩ min.

#### < AMBIENT CONDITIONS >

Install VS-520B units where the following conditions are satisfied.

- Ambient temperature: between -10 and +40°C
- Absence of corrosive liquid or gas in the neighborhood
- Altitude: 1000 m max above sea level
- The atmosphere contains no excessive dust or iron powder
- There is no harmful vibration

The frequency of inspection will depend on the atmospheres in which it is located. If adverse environment, it is better to inspect the unit too frequently to keep the reliability. In performing inspections, refer to Table 10.

## WIRING

VS-520B is in general used as a component in a system of industrial plant. Wiring, therefore, should be made in accordance with the interconnection diagram for entire system.

## TEST OPERATION

### PREPARATION

Before applying power to the VS-520B.

- Disconnect all the connectors for the pulse amplifier power supply on the thyristor module, Fig. 17 on page 16. (The gate circuit is opened.)
- Disconnect the leads between DC outgoing terminals (P, N) and motor terminals. See Fig. 10.

**Note:** If the above precautions are not observed, there is a danger of the VS-520B conducting abnormally large current during tests due to the phase difference between the main AC supply and the control power supply, or to defects in the pulse amplifier power supply.

### Checks Before Applying Power

- With connections around VS-520B  
Use special care when checking the wiring and the impedance of the main circuit (terminals U, V, W), optional field magnetic circuit and the feedback circuit.
- Inside the VS-520B cabinet  
Check external wiring terminals for loose connections, the thyristor module for correct mounting, and all components for dust deposits.

### Applying Power

Measure the main circuit and control circuit supply voltages on the input side of the VS-520B. The voltages between lines shall be within the values shown below.

Main circuit voltage: 170 to 255 V for 200 V class, 340 to 510 V for 400 V class

Control circuit voltage: 170 to 220 V at 50 Hz, 187 to 242 V at 60 Hz

Turn the 200/220 V changeover switch to match the measured voltage of the control circuit. For 210 V or more, turn the switch to "220 V" and for the voltage less than 210 V, turn to "200 V." Where the main and control circuits share the same power supply, follow the measured voltage of the main circuit. The applied voltage of the 400 V class should be one half of the measured voltage.

Apply power to the VS-520B only when all the above conditions are satisfied.

### Checks With Power Applied

1. Measure the supply voltage again.
2. When the main circuit and the control circuit are connected to different power supplies, compare the phase relationship between the two supplies with a synchroscope. (The VS-520B operates properly regardless of the phase rotation direction.)  
After applying power to the VS-520B, carefully check for any abnormal odor, smoke, spark, noise, etc.
3. Direction of air flow of thyristor cooling fan  
For units equipped with a thyristor cooling fan, check the fan for proper operation and for air flow direction. (Normally, air must flow upward.) On the indication plate on the front of the fan of a VS-520B above 1500 A in rated current, an arrow mark (↑) indicating the air flow direction is printed.
4. Operation of under-voltage relay  
As soon as power is applied to the control circuit, the "UV" lamp on the front cover lights. Depress the RESET button (black) and see that the lamp goes out.  
For VS-520B with a self reset circuit, the reset operation is not required.
5. Overcurrent (OC) and overload (OL) relays  
Check the OC and OL relays as follows.

- Turn the potentiometer OC CHK fully clockwise.
- Depress the CHK button (red) and see that the OC and OL lamps light.
- Turn the potentiometer OC CHK to the 0 position and depress the RESET button to extinguish the OC and OL lamps.

When the voltage of CHK 10 (Non-reversible type) and CHK 14 (Reversible type) is 0 V, the check circuit is positively open.

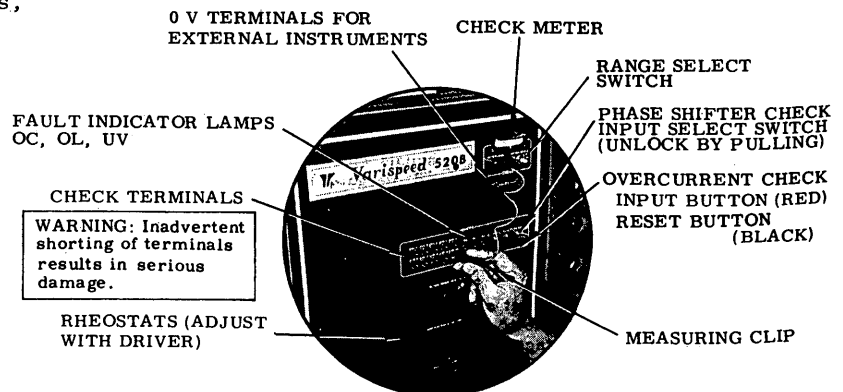

Fig. 8 Front Panel Arrangement

Measurements are possible with external instruments, utilizing the check terminals. Use an instrument with an internal impedance of 50 k $\Omega$  min. Connect it between the terminal marked 0 V and the appropriate check terminal.

### Check Control Signals

Make the checks given in Tables 3 and 4 using the checkers installed on the front cover. For precautions in using the checkers, refer to Fig. 9.

Table 3 CDMR-L5 (Non-reversing Type)

For the start interlock circuit, refer to Table 9.

Check items	Check terminal	Meter range	Indicated voltage	Remarks
Stabilized power supply	CHK6 CHK7	45 V	CHK6...+12 V CHK7...-12 V	—
Non-stabilized power supply (+20% fluctuation)	CHK8 CHK9	45 V	CHK8...+27 V CHK9...-24 V	—
Current controller input	CHK1	15 V	-3 to -7.5 V	To be set within this range (I LIM)
Current feedback	CHK2	3 V	0 V	3 V at 100% current
Current controller output	CHK3	15 V	-1 V*	Start interlock circuit locked (Connection between terminals ① and ② removed)
			0 V	Start interlock circuit released, current reference: 0 V
			+8 V	Start interlock circuit released, current reference: increase
Phase shifter check input	CHK4	15 V	-4 to +9 V	Adjustable with potentiometer PS CHK
Phase shifter input	CHK5	15 V	-1.5 to -9 V *	—
OC check input	CHK10	15 V	+2.5 to +12 V	Adjustable with potentiometer OC CHK

Table 4 CDMR-D5 (Reversing Type)

Check items	Check terminal	Meter range	Indicated voltage	Remarks
Stabilized power supply	CHK10 CHK11	45 V	CHK10...+12 V CHK11...-12 V	—
Non-stabilized power supply (+20% fluctuation)	CHK13 CHK12	45 V	CHK13...+27 V CHK12...-24 V	—
Forward current controller input	CHK1	15 V	-3 to -7.5 V	Input signals are negative To be set within this range
Backward current controller input	CHK2	15 V	-3 to -7.5 V	Input signals are positive
Current feedback	CHK3	3 V	0 V	3 V at 100% current
Current controller output	CHK4	15 V	-1 V*	Start interlock circuit locked (Connection between terminals ③ and ④ removed)
			0 V	Start interlock circuit released, current reference: 0 V
			+8 V	Start interlock circuit released, current reference: up
Phase shifter check input	CHK5	15 V	-4 to -9 V	Adjustable with potentiometer PS CHK
Phase shifter input	CHK6	15 V	-1.5 to -9 V *	—
Zero current detection	CHK7	15 V	0V	With current on
			+9 V	Zero current
Forward pulse amp. power supply	CHK8	45 V	0 V	During backward run
			+25 V	During forward run
Backward pulse amp. power supply	CHK9	45 V	0 V	During forward run
			+25 V	During backward run

\* When the current controller gives proportional control, negative voltage corresponding to the gain appears.

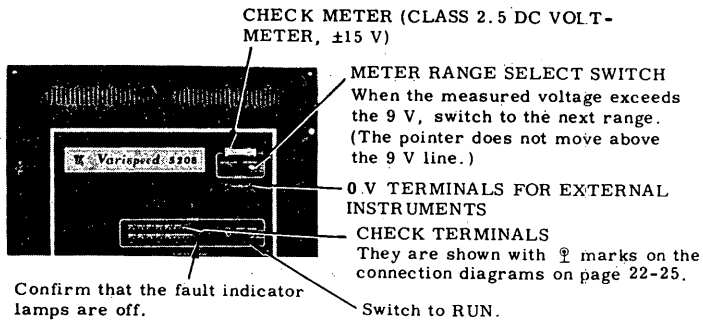

Fig. 9 Cautions in Using Checkers

## NO-LOAD VOLTAGE OUTPUT TEST

When the control circuit is confirmed ready for operation, perform a no-load voltage output test as follows, using the phase shifter input selector switch PS CHK. With this test, the operation of the phase shifter and the thyristors is tested.

### Before Applying Power

1. To re-establish the initial condition, reconnect all the connectors on the thyristor module previously disconnected in preparation for the control circuit checks. (See Fig. 10.)
2. Keep the DC outgoing terminals P and N open.
3. Connect a synchroscope to the DC outgoing terminals P, N on the thyristor module to confirm unit output voltage. The check terminal numbers to be selected for connection for measurement differ by models. For correct terminals, refer to the connection diagrams on Figures 30 to 33.
4. Set the phase shifter test input select switch PS CHK on the front panel to the TEST position. (In order to prevent inadvertent tripping, the switch is provided with a locking mechanism. Set the switch lever to the TEST side, first, slightly pull the lever.)
5. Turn the potentiometer PS CHK (for CDMR-D5, CHK IN) fully counterclockwise.

### Applying Power

Confirm that the gate pulse suppression circuit (39-15 for CDMR-L5, 40-19 for CDMR-D5) is opened.

1. Confirm that a negative voltage carrying uniformly spaced ripples appears as output.
2. Confirm that the output voltage gradually goes positive as the potentiometer PS CHK is turned clockwise.
3. With CDMR-D5 (reversing), change the current reference from negative to positive, and confirm that the same waveform is observed with both the forward and backward converters.

If abnormal ripple waveform is observed, check the gate pulse waveform between the terminals G-K to determine whether the phase shifter or the thyristor is defective.

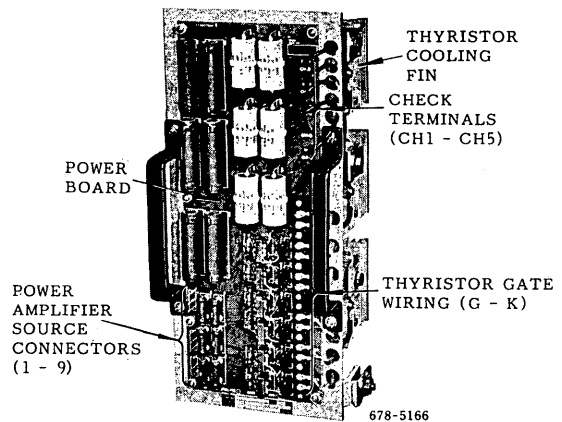

Rated Current 500 A or less

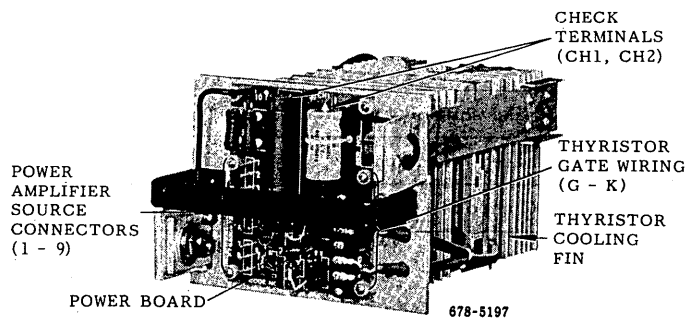

Rated Current 800 A or more

Fig. 10 Thyristor Module Type NPSB-X

## NO-LOAD TEST OPERATION

The VS-520B power converter is designed for use in speed control, voltage control, and current control systems. Here, its use in speed control systems is mainly described.

The VS-520B includes the current minor loop. The major loops are designed upon request, and standard B2 modules will comprise them.

In a no-load test operation, observe the following precautions.

- The motor should be disconnected from the driven machine for the test in order to prevent an accident.
- When there is no means for disconnecting the machine from the motor, fully confirm that the machine can be driven without any danger. If the machine does not permit reverse drive, measures should be taken to eliminate all possibility of driving the machine in the reverse direction.

**Before Applying Power**

- Close the main circuit that has been left open.
- Confirm that the motor and the driven machine are in a condition permitting operation.
- Where a DC tachometer generator is used, make a previous no-load test operation of the speed control circuit with the loop open, before starting actual no-load operations. (In this case, make preparations for measuring the detection voltage of the DC tachometer generator with a multimeter.)

**No-Load Operation (For the system with DC TG)**

Where an AC tachometer generator is used, perform a no-load test operation by following the procedures described on page 9. Where a DC tachometer generator is used, perform a previous check before the no-load test by the following procedures below to check the direction of rotation of the motor and the speed feedback polarity.

1. Set I LIM (with CDMR-D5, I LIM F and I LIM R) to the 0 setting.
2. When no abnormality is found on the motor and driven machine, turn on the power supply switch.
3. Raise the speed reference voltage slightly.
4. After making sure that the motor is in a position at which its starting time is exactly observable, turn I LIM slightly clockwise (with CDMR-D5, turn I LIM F in response to a forward run command).
5. When the motor starts, turn I LIM fully counter-clockwise to the 0 graduation. During this process, confirm the rotating direction of the motor.
6. Slowly turn I LIM clockwise again, and quickly check the polarity of the feedback signal when the motor started to run. Turn I LIM back to the 0 setting.
7. After confirming the motor rotating direction and the feedback polarity as above, turn off the power supply switch, and rewire to make sure that negative feedback signals are generated.
8. Reset the speed reference voltage at zero.
9. Set the I LIM at the nominal value, Table 7.
10. Raise the speed reference voltage gradually.

If the motor does not start when I LIM is turned clockwise to some extent, or if the motor starts with excessive noise, set I LIM back to 0, turn off the power supply switch, and check the motor again.

11. When no defect is present in the motor and VS-520B, increase the speed reference voltage to the maximum value.

12. Closely adjust the relationship between the speed reference voltage and the motor speed by adjusting the tachometer generator feedback, referring to the elementary diagram of the system.
13. Change the speed reference voltage widely with sudden changes to confirm that the control system does not cause hunting. In this case, confirm also that all the control signals are approximately at the levels shown in Tables 5 and 6.
14. Turn off the power supply switch.

**No-Load Operation (For the system with AC TG)**

After confirming the following conditions, operate the motor without load.

- No abnormality is found on the motor and driven machine.
- The potentiometer I LIM is set at the specified position, and the speed reference signal of the system is 0 V.

1. Turn on main and control circuit switches.
2. Make the VS-520B drive system ready for operation.
3. Raise the speed reference voltage gradually.
4. When no defect is present in the motor and VS-520B, increase the speed reference voltage to the maximum value.
5. Closely adjust the relationship between the speed reference voltage and the motor speed by adjusting the tachometer generator feedback, referring to the elementary diagram of the system.
6. Change the speed reference voltage widely with sudden changes to confirm that the control system does not cause hunting. In this case, confirm also that all the control signals are approximately at the levels shown in Tables 5 and 6.
7. Turn off the power supply switch.

**Table 5 Indicated Voltage (CDMR-L5)**

Check items	Check terminal	"METER SCALE"	Voltage	Remarks
Current feedback	CHK2	3 V	0 to +3 V	Varies with no-load current. +3 V at 100% load current.
Current controller output	CHK3	15 V	0 to +5 V	Varies with motor speed. +4 V or so * at 100% speed.

**Table 6 Indicated Voltage (CDMR-L5)**

Check items	Check terminal	"METER SCALE"	Forward and Reverse Runs Indicated voltage	
			Converter	Inverter
Current feedback	CHK3	3 V	0 to +3 V	
Current controller output	CHK4	15 V	0 to +5 V	0 to +3 V
			* +	

\* Where current is only proportionally controlled (with counter emf compensation), the voltage becomes nearly 0 at 100% speed.

† Where current is integrally controlled, the voltage becomes nearly 0 at 100% speed when the counter emf compensation function is utilized.

## LOAD TEST

Perform test operations in accordance with the separate operation manual.

1. Couple the driven machine to the motor.
2. After confirming that no abnormality is found on the driven machine, and that the speed setting is 0, turn on the power supply switch.
3. Carefully observing the conditions of the load machine, gradually raise the speed reference voltage, and confirm that the motor and the load machine rotate correctly.

## ADJUSTMENT

All the adjustments described in this section have been made by our technical service engineers. (A final setting list shall be submitted.)

When the control board is replaced, check the potentiometers with  in Table 7 (non-reversing type) or Table 8 (reversing type).

## ADJUSTMENT ITEMS

There are the following two control boards, one for non-reversing operation and the other for reversing operation.

- Control board for CDMR-L5 (non-reversing type): JPDC-C020
- Control board for CDMR-D5 (reversing type): JPDC-C021

Table 7 Potentiometer Adjustment on Control Board JPDC-C020 (non-reversing type)

Refer to Fig. 9 for approx. mtg. locations.

Adjustment method	Code	Function or name	Adjustment	Specification
Potentiometer	I LIM*	Current limit adjustment	 Limit value increases	-3V/100% load current
	OFF SET ADJ	Current control offset adjustment	-voltage (°) +voltage	Adjusted before shipping (paint-locked)
	I FB*	Current feedback adjustment	 I FB increases	+3V/100% load current
	I GAIN*	Current controller proportional gain adjustment	 Gain increases*	0.3 to 1.8 times
	PS CHK	Phase shifter test input	-voltage (°) +voltage	Independent from control, (-4 to +9 V)
	CEMF C*	CEMF compensation adjustment	 Gain increases	0.4 to 0.8 times
	PS BIAS*	Phase shift adjustment	 Gate pulse leads	Variable over 160 to 80°el at 50/60 Hz
	KIPP*	Kipp position adjustment	 Phase angle of lag limit position leads	Variable over 145 to 155°el at 50/60 Hz
	α LIM*	α limit adjustment	 Phase angle of α limit leads	Variable over 15 to 30°el at 50/60 Hz
	OL %*	Overload current tripping value setting	 Tripping value increases	Trip point: 100 to 300%
	OL TIME*	Overload current tripping time setting	 Tripping time increases	Standard: 10 to 100 sec
	OC %*	Overcurrent tripping value setting	 Tripping value increases	Trip point: 100 to 400%
	OC CHK	Overcurrent relay test input	 Input increases	Variable over 2.5 to 12 V
Replacing resistors (by soldering the pins)	1PSR-6PSR	Phase lag angle adjustment of PS filter	Standard: 4.7 kΩ Correction of phase difference	Gate pulse difference adjusted within ±2°el before shipment
	69R-74R	Gate pulse width adjustment	Standard: 22 kΩ Correction of gate pulse width	Gate pulse width adjusted to 40 to 60°el before shipment
	UVR	Undervoltage tripping value setting	Standard: 5.1 kΩ (Set range: -10% UV/kΩ)	70 to 80% of nominal voltage
Replacing capacitor (by soldering the pins)	ICC, 2CC	Current controller integrating time	Standard: 2.2 μF (each can be combined with 10 μF polarized Ta capacitor)	13 to 120 ms
	OLC	Overload characteristics	Standard: 100 μF (Replace when time must be less than 10 sec)	10 to 100 sec
Short-circuiting jumper	I LIM	Internal current limit selection	Short-circuit when using internal circuit	Standard: short-circuit
	2CC	Current controller proportional control selection	Short-circuit for proportional control	Standard: open
	OPP	Current controller proportional control	Open for proportional control	Standard: short-circuit
	A, B, C, D, E	Current feedback adjustment	Open according to specification	+3V/100%
Selector switch (not on board) See Fig. 3.	ISW	200/220 V selection	200V: 210V max. 220V: Less than 210V	Turn the knob according to control power supply voltage.

\* When control board is replaced, set to approx. dial positions.

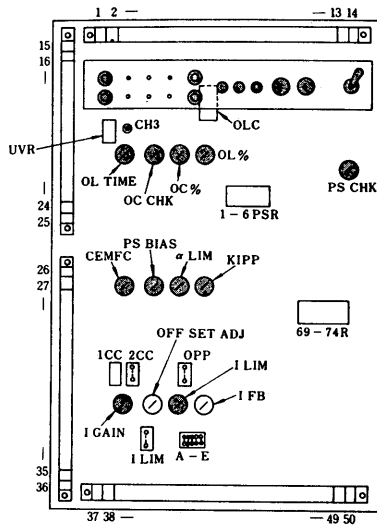

Fig. 11  
Type JPDC-C020

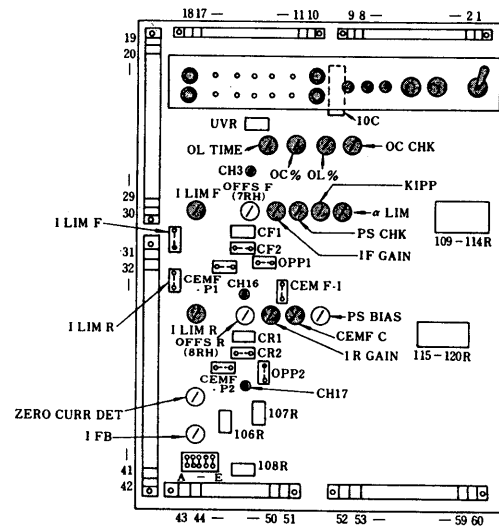

Fig. 12  
Type JPDC-C021

Check Points for PCB Replacement (17 Points)

Check Points for PCB Replacement (30 Points)

Table 8 Potentiometer Adjustment on Control Board JPDC-C021 (reversing type)

Refer to Fig. 10 for approx. mtg. locations.

Adjustment method	Code	Function or name	Adjustment	Specification
Potentiometer	I LIM F*	Fwd. current limit adjustment	Limit value increases	-3V/100% load current
	I LIM R*	Rev. current limit adjustment	Limit value increases	+3V/100% load current
	OFFS F OFFS R	Current control offset adjustment	-voltage (°) +voltage	Adjusted before shipping (paint-locked)
	I FB*	Current feedback adjustment	I FB increases	+3V/100% load current
	IF GAIN IR GAIN*	Current controller gain adjustment	Gain increases	0.3 to 1.8 times
	PS CHK	Phase shifter test input	-voltage (°) +voltage	Independent from control (-4 to +9V)
	CEMF C*	CEMF compensation adjustment	Compensation increases	0.3 to 1.7 times
	PS BIAS	Phase shift adjustment	Gate pulse leads	Variable over 160 to 80°el at 50/60 Hz
	KIPP*	Kipp position adjustment	Phase angle of lag limit position leads	Variable over 145 to 155°el at 50/60 Hz
	α LIM*	α Limit adjustment	Phase angle of lead limit	Variable over 15 to 30°el at 50/60 Hz
	ZERO CURR DET*	Comparison level adjustment for zero current detector	Detection level increases	0 to 10%
	OL %	Overload current trip value setting	Trip value increases	Trip point: 100 to 300%
	OL TIME	Overload current trip time	Trip time increases	Standard: 10 to 100 sec
	OC %	Overcurrent trip value setting	Trip value increases	Trip point: 100 to 400%
	OC CHK	Overcurrent relay test input	Input increases	Variable over +2.5 to +12 V independent of control
Replacing resistors (by soldering the pins)	109 to 114R	Phase lag angle adjustment of PS filter	Standard: 1.5 kΩ (Lag: +3°el/kΩ)	Gate pulse difference adjusted within +2°el before shipment
	115 to 120R	Gate pulse width adjustment	Standard: 22 kΩ (Change width +2°el/kΩ)	Gate pulse width adjusted to 40 to 60°el before shipment
	UVR	Undervoltage tripping value setting	Standard: 5.1 kΩ (Set range: ±10%UV/kΩ)	70 to 80% UV
	106, 107R	Comparison level adj. for torque reference polarity detector	Standard: open (Setting ex. 12% at 2M)	0%
Replacing capacitors (by soldering the pins)	CF1, CR1 CF2, CR2	Current control integrating time setting	Standard: 2.2 μF (Each can be combined with 10 μF polarized Ta capacitor)	13 to 120 ms
	IOC	OL relay time setting	Standard: 100 μF	10 to 100 sec
Short-circuit jumpers	I LIM F I LIM R	Int. current limit selection	Short-circuit when using int. circuit	Standard: short-circuit
	CF2, CR2	Current controller prop. control selection	Short-circuit for proportional control	Standard: open
	OPP1 OPP2	Current controller prop. control selection	Open for prop. control	Standard: short-circuit
	CEMF P1 CEMF P2	CEMF compensation for proportional control	Short-circuit for compensation	Standard: open
	CEMF J1	CEMF compensation for integral control	Short-circuit for compensation	Standard: short-circuit
200/220V Selector switch (not on board) (See Figs. 4 and 5)	A, B, C D, E	Current feedback	Open according to specifications	+3V/100%
	ISW	200/220V selection	200V: 210V max. 220V: Less than 210 V	Select according to control power voltage

\* When control board is replaced, set to approx. dial positions.

## ADJUSTMENT METHOD

Where detail of adjustments in Tables 7 and 8 is necessary, refer to the followings.

### Overcurrent Relay

These set values are determined as to give complete protective coordination on the basis of system design data and the relay is factory set. If the set values are subject to change, consideration must be given to the load conditions and thyristor ratings.

#### 1. Overcurrent Setting (Instantaneous trip value)

Setting range: Full CCW turn: 100%;  
Full CW turn: 400% (+3 V/100%)

Normally, in practice, the overcurrent trip value is set around 1.25 times the current limit value (I LIM), to prevent malfunctional operation by current ripples, etc.

Setting method: (in preparation, turn the OC% knob fully clockwise)

- i. Depress the OC CHK button (red) on the front cover. (The check input voltage is retained.)
- ii. Measure the terminal voltage at CHK 10 (for non-reversing type) or CHK 14 (for reversing type), and adjust the potentiometer OC CHK until the measured voltage reaches pick up voltage specified in the customer requirement (6 V for 200%)
- iii. Turn carefully the potentiometer counter-clockwise, or release OC CHK button to open the check circuit. The OC indicator lamp goes out.
- iv. Turn the OC CHK fully counter-clockwise, or release OC CHK button to open the check circuit. The OC indicator lamp goes out.

#### 2. Overload Level (Overload current trip value) and OL TIME (trip time)

Setting range: OL %: Full CCW turn: 100%, full CW turn: 300%  
OL TIME: Shortening by CCW turn, lengthening by CW turn. For operation characteristics, refer to Fig. 13.

Setting method: To set the overload protection relay to suit the required specifications, proceed as follows.

#### Guide to overload protection setting

When the overload detection level, max. permissible overload level, and the time between detection and tripping are respectively to be set at 150%, 200%, and 20 sec:

Max. permissible overload (K) = 200%

Overload detection level (K<sub>o</sub>) = 150%

Then,  $K - K_o = 200\% - 150\% = 50\%$

In Fig. 13, for an overload of 50% and a trip delay time of 20 sec, OL TIME scale reading of "3" is given (rough setting).

Fine setting is made as follows:

- i. Turn on the main and control-circuit switches.
- ii. To measure CH 3 voltage, remove the front cover. (Turn off the power supply switch.)  
Note) When checking the operation only, the front cover need not be removed.
- iii. With the main and control power supplied, set the OL% so that the CH 3 voltage reaches a level corresponding to 150% load (-3 V x 1.5 = -4.5 V)
- iv. Depress the OC CHK button, and set the OC CHK potentiometer so that the CHK 10 (CHK 14) voltage corresponds to 200% load (+6 V)
- v. Depress the RESET button (black), and confirm turning off the OL indicator lamp.
- vi. Depress the CHK button, and measure the time until the OL indicator lamp lights, with a stopwatch or your watch. Measure several times and adjust with the OL TIME until the trip delay time becomes 20 sec.
- vii. After measurement, turn the OC CHK knob fully counter-clockwise to positively open the OC CHK circuit.

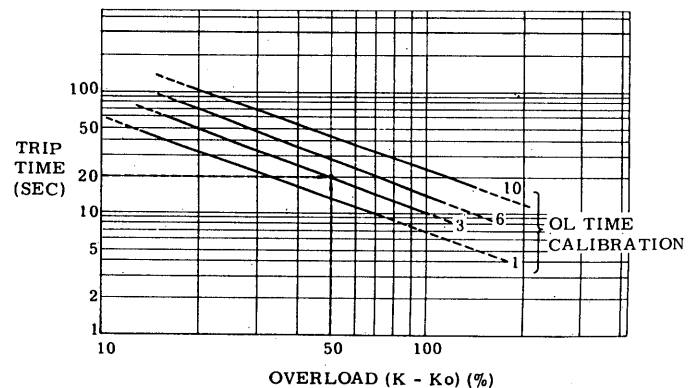

Fig. 13 Overload-trip Time Characteristics



## PS BIAS (Phase Shifter Bias) Adjustment

This adjustment is for determining the trip reference point for the phase shifter.

·Setting range: Full CCW turn: 150° el,  
full CW turn: 80° el at 50/60 Hz

·Standard setting:

For current controller proportional control:  
With the current reference voltage 0, turn PS BIAS clockwise, until the main circuit current starts to flow. The position immediately before the current start is the set value.

For current controller integral control: With the current reference voltage 0, adjust it until the gate pulse position becomes 150° el. (To prevent motor rotation at creep speed under controller temp. drift.)

## CEMF C (Counter Electromotive Force Compensation) Adjustment

In the current loop, counter electromotive force acts as a disturbance. In order to obtain optimum performance, a compensating electromotive force has to be biased on the phase shifter, depending on the control mode.

### 1. For proportionally controlled current controller

The optimum value is determined from the value of motor acceleration current (current limit value) as observed on a synchroscope. (The condition described in "No-load Operation" on page 9 is desirable.)

- i. First, turn the CEMF C fully counter-clockwise.
- ii. Turn the CEMF C clockwise until the acceleration current comes to show a curve as shown in Fig. 14 on the synchroscope screen.

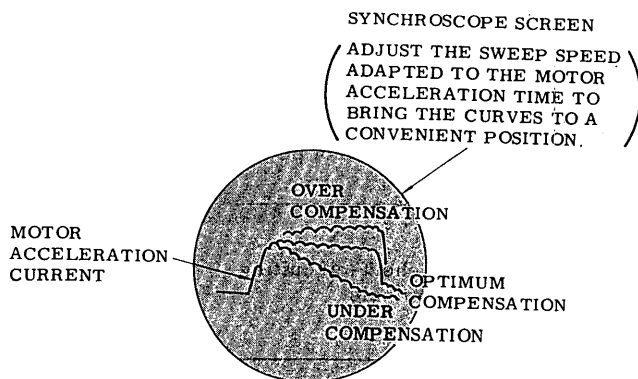

Fig. 14 Adjustment of CEMF C

### 2. For integrally controlled current controller

Do not make any compensation when the motor is driven in one direction only.

For a motor driven in both directions, the dead time in reversing the driving direction is shortened by the compensation to the time as in the case of proportional current control.

Make adjustments as follows.

- i. Turn the CEMF C fully counter-clockwise to run the motor at the highest speed.
- ii. Observe the voltage at CHK 4.
- iii. Observe the voltage at CH 16, for forward motor rotation, or at CH 17, for backward motor rotation, and turn the CEMF C knob gradually clockwise until the observed voltage becomes equal to the voltage measured in procedure ii. above, refer to Figs. 9 and 10.

### $\alpha$ LIM (Lead restriction of angle of delay) Adjustment

The control lag angle ( $\alpha$  angle) should be prevented from leading excessively to eliminate misfiring or the loss of gate pulses. This angle lead is further limited in reversing control by the inverter voltage (to be determined by the KIPP pulse position).

Standard setting: Reversing control: 30° el  
Non-reversing control: 20° el

### KIPP (Lag restriction of angle of delay) Adjustment

Where the motor is driven only in one direction, this adjustment need not be required. However, where the motor is driven in both directions, if the phase control angle lags excessively in the inverter function range, commutation failure and other serious accidents may be caused. The setting value is determined during the system design with consideration of the following items.

- Voltage lowering at the power supply and the rated motor voltage.
- Commutation overlapping angle
- Thyristor turn-off time
- Gate pulse unbalance angle

(Standard setting: 150°el)

OFFS F, OFFS R (Offset adjustment for reversing type) Adjustment

To adjust the offset, including the offset of external circuits, proceed as follows.

1. Forward drive adjustment (release the start interlock)
  - Connect a 10 kΩ resistor across the 107R by clipping.
  - Turn the current reference to a negative voltage. Then the output of the reversing logic circuit will be kept on positive hold regardless of the current reference value.
  - Change the current reference to 0 V, and turn the potentiometer OFFS F (7RH) until the voltage at CHK 4 becomes 0.
  - Be sure to disconnect the 10 kΩ resistor after adjustment.

2. Reverse drive adjustment









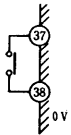
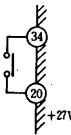

- Insert a 10 kΩ resistor in the space for 106R and connect it across 106R by clipping. Change the current reference to a positive voltage value. The circuit is held on the reverse side.
- Turn the current reference to 0 V, and adjust the OFFS R (8RH) until the voltage at CHK 4 becomes 0.
- Be sure to disconnect the 10 kΩ resistor after adjustment.

**EXTERNAL ADDED SEQUENCE CIRCUITS**

Check the functions by referring to the submitted drawings.

Table 9 Function of External Sequence Circuit

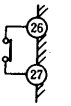
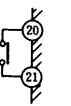
For wiring, use only twisted wires, less than 5 m in length.

Functions	Terminals		Cautions	
	Non-reversible JPDC-C020	Reversible JPDC-C021		
Interlock circuit (Start interlock)			To be connected to the system to make the control circuit operative only when the start conditions are satisfied. When the VS-520B alone is to be tested, short the terminals shown at the left.	
Gate pulse elimination (Elimination of the pulses while the main circuit is open)			When these terminals are shorted, gate pulses are eliminated.	
OC	External trip circuit (Ext. gate block)			When these terminals are shorted, an ext. gate block is applied. (Delay time: 2 ms max.)
	Reset circuit (Cleaning fault memory)			When this circuit is not used, short-circuit these terminals.
	-24 V power supply (Ext. power source for display)			Separate power supply for display during control power fault
UVR	Reset circuit (Elimination of fault memory)			Reset by short-circuiting these terminals
	+24 V power supply (Ext. power source for display)			Separate power supply for display during control power fault

# MAINTENANCE

## PERIODIC INSPECTION

Make careful inspection at regular intervals, at least once a month, by referring to Table 10.

Table 10 Check List for Periodic Inspection

Points to be checked	Corrective action	Remarks	
Cooling fan (Optional)	<ul style="list-style-type: none"> <li>Undue noise</li> <li>Abnormal vibration</li> </ul>	Check for foreign matter and remove if any.	Guide for replacement intervals <ul style="list-style-type: none"> <li>For rated currents from 200 to 900 A Every 30000 hours</li> <li>For rated currents 1500 A and 1650 A Replacement of motor bearings every 20000 hours</li> </ul>
Air filter (Optional)	<ul style="list-style-type: none"> <li>Dust clogging</li> </ul>	If half of effective area is choked with dust, wash in a solution of detergent.	<ul style="list-style-type: none"> <li>Washing every 3 to 6 months (depending upon operating conditions)</li> <li>Replace with new filter, when washed about ten times.</li> </ul>
High speed relay (OC, OL) (Operate on front cover)	<ul style="list-style-type: none"> <li>Set values</li> <li>Trip values</li> </ul>	Replace with new one if it does not operate correctly.	<ul style="list-style-type: none"> <li>To provide positive operation at emergency.</li> </ul>
Others	<ul style="list-style-type: none"> <li>Dirts and dust accumulated</li> <li>Hand tools left in the equipment</li> <li>Bolts or nuts not loosened</li> </ul>	Clean by means of suction type device.	<ul style="list-style-type: none"> <li>Dust and dirts on thyristors and cooling fins deteriorate heat dissipation, and increase insulation resistance, Fig. 14.</li> <li>Special locking means are provided for nuts to fix thyristors and busbars.</li> </ul>
Surge absorber fuse (Check on front cover)	<ul style="list-style-type: none"> <li>White-blown indicator</li> </ul>	Replace in reference to "Replacing surge absorber fuse on page 17.	<ul style="list-style-type: none"> <li>Long term operation with blown-fuse may injure thyristors.</li> </ul>
Thyristor fuse (Check on front cover)	White rod indicator	Refer to Table 11.	—

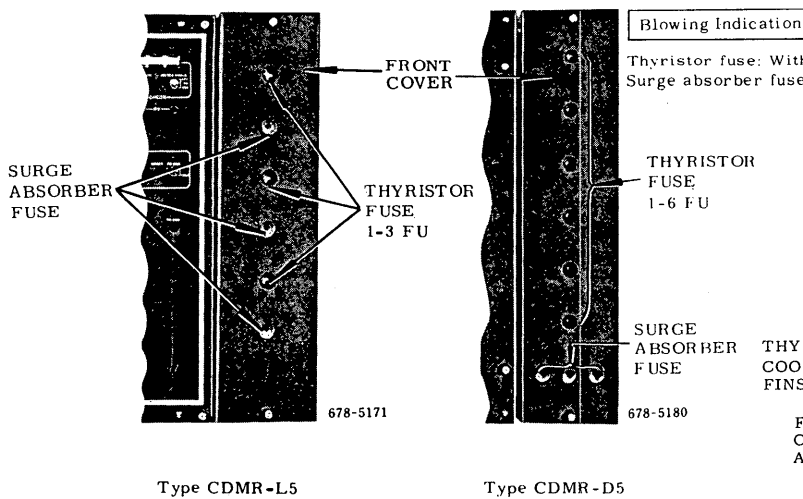

Fig. 15 Fuse Locations

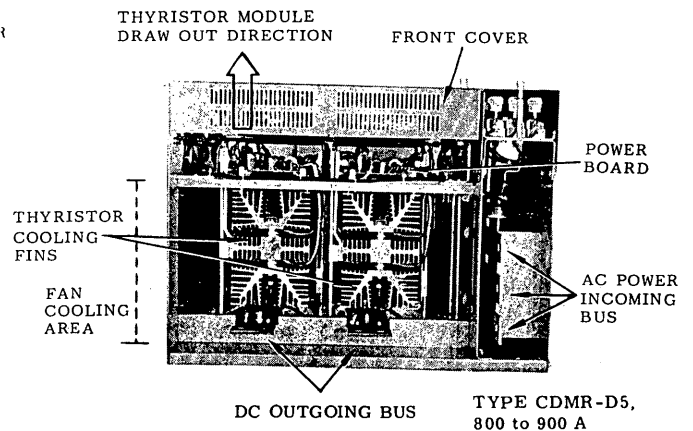

Fig. 16 Ventilating System Viewed from Bottom of the Unit

## PARTS REPLACEMENT

"CAUTION" It is essential that the apparatus be isolated and proved dead. Prior to fault parts replacement, be sure to remove possible causes.

### Replacing Thyristors

To replace thyristors, dismount the thyristor module and place it on the work bench. Screw wrenches for M8, M10, and M12, and a socket wrench for M10 are required.

1. Unscrew the panel lock screws and swing open the front panel. (Figs. 3 to 5)
2. Remove the connector for the PS power supply as shown in Fig. 17.  
(If the connector is not readily removable, lift up the board slightly with a screw driver, taking care not to damage the board.)
3. Loosen the mounting and connecting nuts for the thyristors (Fig. 18) and remove the thyristor modules as shown in Fig. 19.

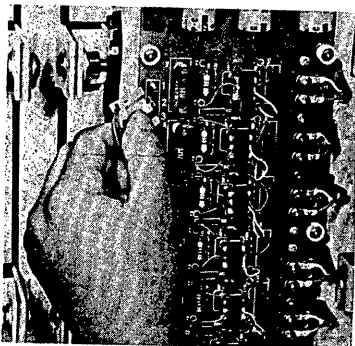

678-5183

Fig. 17 Connectors for Pulse Amplifier

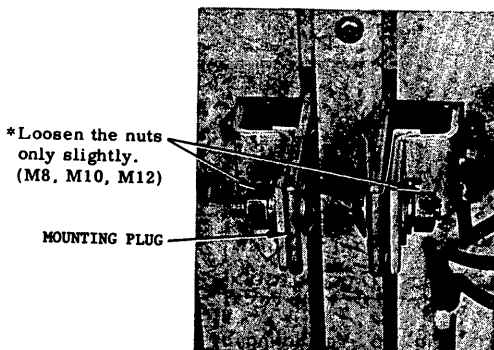

678-5164

Fig. 18 Semi-plug-in Stack

4. Unscrew the clamp nuts with a socket wrench. (See Fig. 20.)

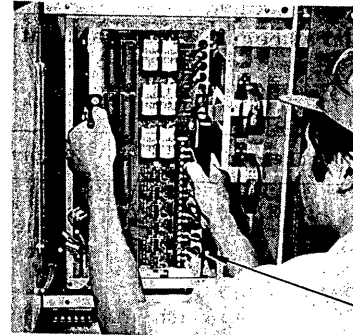

TYPE  
CDMR-L5, 300 A

Handle with care so as not to damage components.

678-5173

Weight: 80 - 500 A modules: 12 kg max.  
800 - 1650 A modules: 8 kg max.

Fig. 19 Dismounting Thyristor Modules

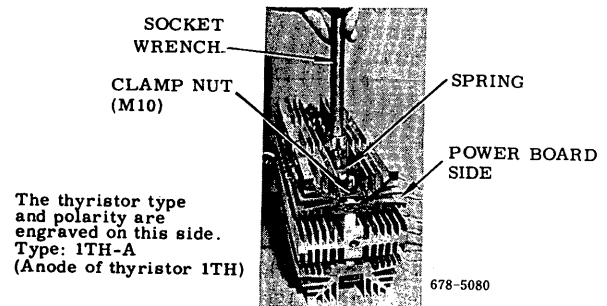

678-5080

(a) Rated Currents 500 A or Below

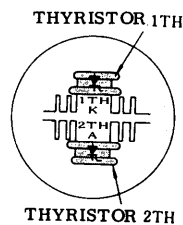

678-5207

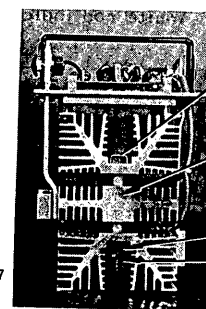

(b) Rated Currents 800 A or Above

Fig. 20 Thyristors and Fin

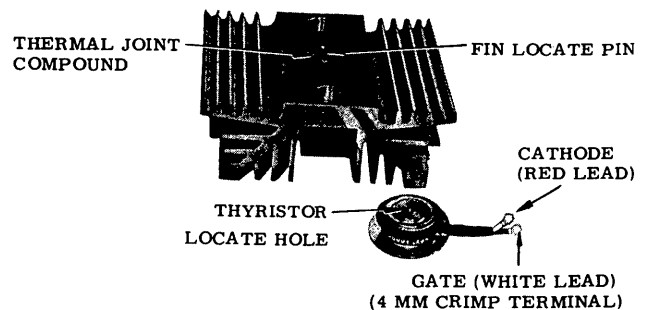

Fig. 21 View After the Removal of Thyristor

**5. Remove the thyristor**

Clean the joint surfaces between the thyristors and the fins, and apply thermal joint compound thinly on both surfaces. (See Fig. 21.)

**6. Replacing thyristors should be obtained from our agents.**

When two thyristors are to be connected in parallel for nominal currents 1500 A and 1650 A, the two must have a comparable forward voltage drop value.

**7. Confirm the polarity of the thyristors, and align the locating pin on the fin and the locating hole on the thyristor. (Refer to Figs. 20 and 21.)**

**8. With the spring and the fin held parallel, tighten the clamp nuts with fingers as hard as possible. Tighten the nuts three times alternately with a socket wrench, 1/4 turn at a time.**

**9. Insert the thyristor module and the connectors in their respective original positions, and firmly tighten the mounting nuts.**

**NOTE**

For thyristors with rated current of 900A and 1650A, renewal parts are changed from type 800P 15H, 800A, 1500V (SCR 000166, made by NEC) to type SF 500 U27, 500A, 1600V (SCR 000229, made by TOSHIBA).

The new type will be interchangeable with conventional types. If type 800P 15H in which two thyristors are to be connected in parallel is changed to type SF 500 U27, replace the thyristors at the same time. This applies to the thyristor types listed below.

Rated, Code Type	Nominal Voltage	Nominal Current	Code No.
NON-REVERSING DRIVES	460V	1650 A	EPJ00444X
REVERSING DRIVES	460V	1650/1650 A	EPJ00445X
		1650/ 900 A	EPJ00443X

Note: Where two elements per thyristor are used, the thyristor should be replaced at the same time.

**Replacing Fuses, Control Board, and Surge Absorber**

**REPLACING THYRISTOR FUSE**

When the fuse blows, indicating rod comes out. Unscrew the two M10 mounting screws, and two terminals for blown fuse detection.

**REPLACING SURGE ABSORBER FUSE, REPLACING CONTROL CIRCUIT FUSE**

When the fuse blows, the white indicator comes out. Replace only the fuse element.

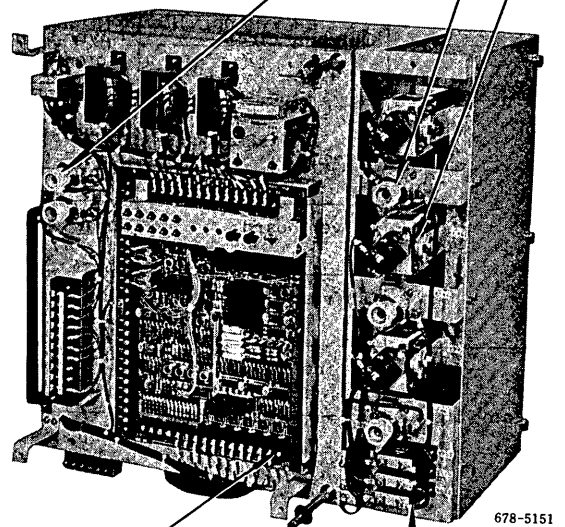

678-5151

**REPLACING CONTROL BOARD**

- Disconnect all the wires connected to the control board by unscrewing their screw terminals.
- Remove the control board by unscrewing its six mounting screws.

**REPLACING SURGE ABSORBER**

Unscrew the two mounting screws and disconnect two wires to dismount the surge absorber.

Fig. 22 Parts Replacement

**Replacing the Fan Unit UNIT**

Remove it by unscrewing the two mounting screws.

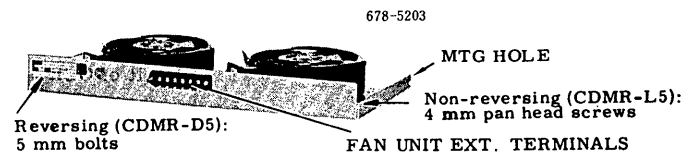

Fig. 23

# TROUBLESHOOTING

Table 11 contains information which will be helpful in most problems of VS-520B.

Table 11 Troubleshooting of VS-520B

Symptom	Checking Points	Possible Cause	Diagnostics	What to do
1 OC lamp lights	Control board	Too low set of OC %	Raising of the set value.	Refer to "Adjustment Method"
		OC CHK circuit being closed	—	Turn the OC CHK fully counter-clockwise.
		Too high set of I LIM	Lowing of the set value.	Refer to the Table 7.
	Control power supply	Drop of control power supply voltage	Refer to 3 UV lamp lights.	
	Outgoing circuit	Layer short-circuit of the motor winding	Open the main outgoing terminals of VS-520B and drive it individually. If VS-520B runs successfully, the motor faults or connection between VS-520B and the motor is poor.	Remedy of the motor
		Grounding of the motor branch circuit		
	Power board	Poor characteristics	Refer to "Troubleshooting"	Replacement of the thyristor module
Thyristor	Detrioration	Refer to "Troubleshooting"	Replacement of the thyristor	
2 OL lamp lights	Control board	Too low set of OL %	Raising of the set value	Refer to "Adjustment method"
	Motor, driven machine	Longer starting time	Too high load inertia	Correct to rated load.
		Lock of the motor or a driven machine	Dismantling and check	Refer to an instruction on motor or driven machine.
		Overload	Check of motor capacity	Correct to rated load.
3 UV lamp lights	Control power supply	Under voltage, no voltage, or extreme voltage fluctuation	Check of voltages between phases.	Refer to the Table 4
	Potential transformer for control power supply	Breaking of a coil or layer short circuit	Check of the coil impedance	Replacement of the transformer
		Poor connection	Wiring check	Rewiring
4 Thyristor fuse blows	Outgoing circuit	Layer short-circuit of the motor winding	Open the main outgoing terminals of VS-520B and drive it individually. If VS-520B runs successfully, the motor faults or connection between VS-520B and the motor is poor.	Remedy of the motor
		Grounding fault		Fixing of the fault part
	Thyristor	Deterioration	Refer to "Troubleshooting"	Replacement of the thyristor module
	Main power supply	Phase failure	Blowing of fuse or poor connection	Fuse replacement or rewiring
		Power failure	Measurement of terminal voltage at feeder	Call "Power company"
	Control board	Too high set of OC %	Lowing of the set value	Refer to "Adjustment Method"
		Fault of OCR	Operation check, refer to "Adjustment Method"	Replacement of the control board
		Poor PS control	Refer to "Troubleshooting"	

Table 11 Troubleshooting of VS-520B (Continued)

Symptom	Checking Points	Possible Cause	Diagnostics	What to do	
5 Blowing of the surge absorber fuse	Main power supply	Excessive surge on the main circuit (ex. lighting surge)	Check lightning strike	Replacement of the fuse	
		Transmission of switching surge generated at a power transformer primary	—	Call "Power Company"	
6 Motor does not start	Ext. control circuit	Incomplete starting interlock	Abnormal of PS input voltage (Tables 5 and 6)	Check start interlock.	Refer to Table 9.
	Control board	Too low set value of "I LIM" (I LIM F, I LIM R)		Refer to Tables 7 and 8.	Correction
		Fault of the control board.	Refer to "Troubleshooting"	Replacement of the control board	
	Ext. control circuit	Reference contact for gate pulse elimination circuit does not close.	PS input voltage is normal. (Tables 5 and 6)	Check gate pulse elimination circuit	Refer to "Diagnostics".
	Control board	Fault of PS Fault of F/R change-over circuit		Refer to "Diagnostics"	Replacement of the control board.
Refer to Table 10					
7 Motor does not rotate at rated speed (low or high).	Supply voltages	Beyond the values given on the Table 3	Refer to Tables 9 and 10.	Correction	
	Control board	Uncorrect set of I LIM (I LIM F, I LIM R)			
		Uncorrect set of I FB			
		Uncorrect set of CEMFC (for proportional control by a current amplifier)			
8 Motor rotates with unstable speed.	Control board	Too high set of IF GAIN (IF GAIN, IR GAIN)	Refer to Tables 9 and 10.	Correction	
		Distortion of output current waveforms	Observe waveforms by means of a synchroscope connecting across the outgoing terminals P and N. (Refer to Fig. 24 )	Refer to "Diagnostics"	
		Fault of F/R change-over circuit	Refer to Table 10.	Correction	
	Current reference	High ripple content	Measure waveforms by means of a synchroscope (terminal 34 for type CDMR-L5, terminal 21 for type CDMR-D5)	Insert filtering circuit.	

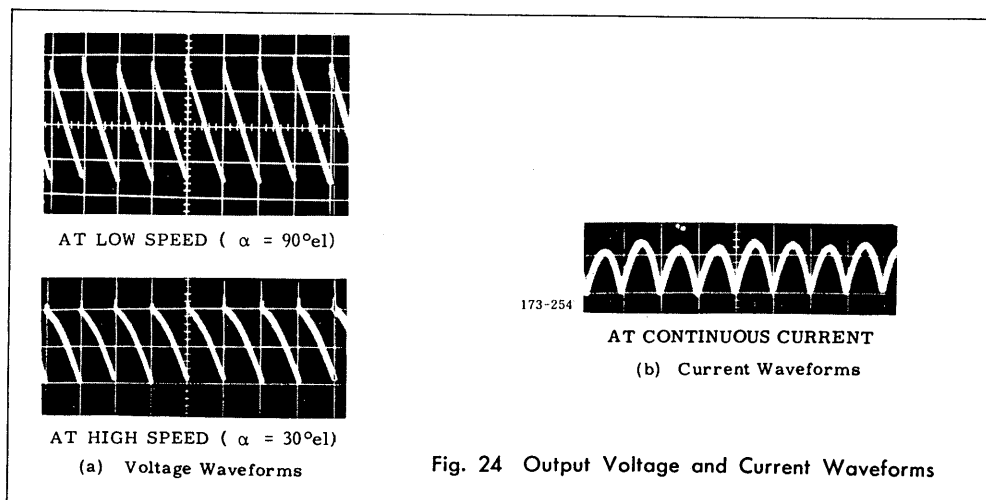

## DIAGNOSTICS

When VS-520B shows any of abnormalities, disconnect the power supply switch and make the following checks to determine the cause. Prior to the checks, perform the operations on "Preparation".

1. Check control signals, see tables 3 or 4.
2. Check of PS output

Observe voltage waveforms by connecting a synchroscope to the following terminals on the control board. The waveforms can be changed by controlling the current reference or control of the rheostat PS CHK with turning the change-over switch PS CHK to TEST. When these waveforms are exactly alike in shapes as the waveforms shown in Fig. 25, PS output is deemed sufficient.

- Terminals to connect the synchroscope

Control board type JPDC-C020 ... ④④ - ④⑨  
Control board type JPDC-C021 ... ④⑨ - ⑥⑥

- Waveforms

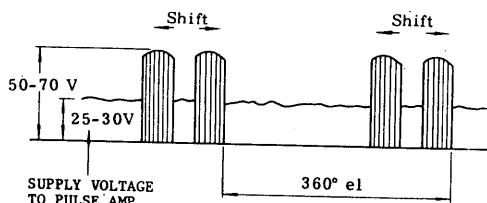

Fig. 25 PS Output Waveforms

- If abnormal waveforms are observed, replace the control board with new one, refer to Fig. 22.

### 3. Check of the thyristor gate pulse

Observe pulse waveforms by a synchroscope connecting across gate and cathode.

- Thyristor gate and cathode terminals ..... Fig. 10
- Gate pulse waveforms ..... Fig. 26

If abnormal gate pulse waveforms are observed, the power board is deemed fault. Replace with new one.

### 4. Check output voltage waveforms by performing the test given in "No-load Operation". As the result of test, a faulty part is distinguished the thyristor from phase shifter.

### 5. Check of thyristors

- Check by a synchroscope ... (On-load test). The test is carried-out to find a faulty thyristor by checking of voltage waveforms across the terminals A and K. See Fig. 25.

- Check by a tester  
Remove the thyristor, refer to "Replacing thyristors." Make a conduction check as shown in Figs. 28 and 29.

### 6. If no defect is found, check also interconnection wiring or external control circuits.

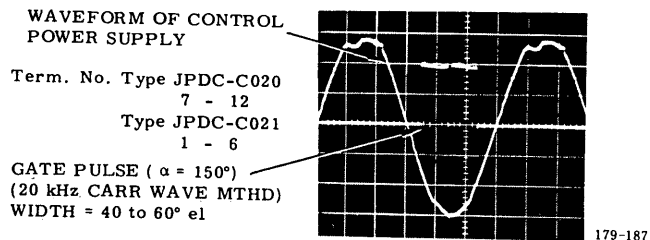

When thyristor turns off

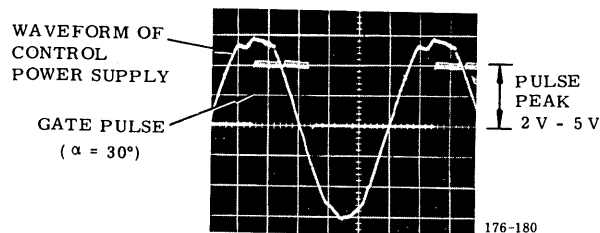

When thyristor turns on

Fig. 26 Gate Pulse Waveforms

AT LOW SPEED ( $\alpha = 90^\circ$ )      AT HIGH SPEED ( $\alpha = 30^\circ$ )

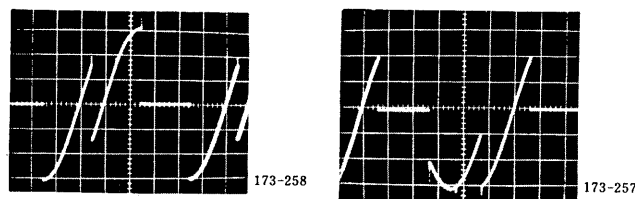
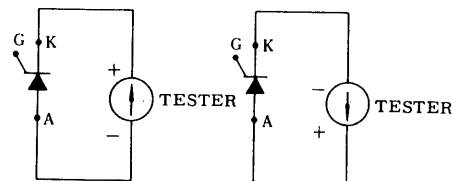
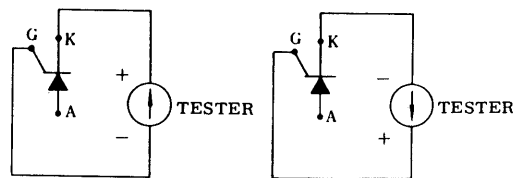

Fig. 27 Thyristor Voltage Waveforms across Terminals A-K



( IF TESTER READING IS ZERO ON EITHER ONE OF TWO MEASUREMENTS. THYRISTOR MODULE IS DEFECTIVE. )

Fig. 28 Testing Module by Connecting Tester across A and K



( IF TESTER READING IS ZERO OR  $\infty$  ON EITHER ONE OF TWO MEASUREMENTS. THYRISTOR MODULE IS DEFECTIVE. )

Fig. 29 Testing Module by Applying Tester across G and K



# SPARE PARTS

Table 12 lists the recommended spare parts for one VS-520B. Keep always minimum insurance spare parts on hand to protect the units against costly downtime. When ordering spare

parts, specify complete nameplate rating and description (type, code no., etc.) of the parts wanted, and quantity desired. Address to the nearest Yaskawa representative office.

**Table 12-1 Spare Parts and Minimum Insurance Quantity for One VS-520B (CDMR-L5, Non-Reversing Drive)**

Thyr. Conv. Unit		Thyristors (Maker)		Thyristor Fuses*		Cont. Ckt. Fuses		Surge Absorb Fuses	
Code Rating	Type, Rating Code	Qty	Type, Rating Code	Qty	Type Rating Code	Qty	Type Rating Code	Qty	
Rated Voltage 230 V	EPJ00422X 80A	2	SF100L27, 100 A, 800 V SCR000145 (Toshiba)	3	AfoC 30/3, 3 A, 100 lA Fu000329	2	AfoC 30/30, 30 A, 100 lA Fu000334	3	
	EPJ00423X 200A		CS5 F-200, 200 A, 500 V Fu000609						
	EPJ00425X 300A	SF250L27, 250 A, 800 V SCR000147 (Toshiba)	CS5 F-350, 350 A, 500 V Fu000612						
	EPJ00427X 500A	SF400L27, 400 A, 800 V SCR000149 (Toshiba)	CS5 F-500, 500 A, 500 V Fu000615						
Rated Voltage 460 V	EPJ00446X 80A	2	SF100U27, 100 A, 1600 V SCR000146 (Toshiba)	3	AfoC 30/5, 5 A Fu000330	2	AfoC 30/30, 30 A, 100 lA Fu000334	3	
	EPJ00424X 200A		CS5 F-200, 200 A, 500 V Fu000609						
	EPJ00426X 300A	SF250U27, 250 A, 1600 V SCR000148 (Toshiba)	CS5 F-350, 350 A, 500 V Fu000612						
	EPJ00428X 500A	2	SF400U27, 400 A, 1600 V SCR000150 (Toshiba)						CS5 F-500, 500 A, 500 V Fu000615
	EPJ00429X 800A		CS5 F-600, 600 A, 500 V Fu000616						
	EPJ00430X 900A	2	SF500U27, 500 A, 1600 V SCR000229 (Toshiba)						CS5 F-800, 800 A, 500 V Fu000687
	EPJ00431X 1500A	4	SF400U27, 400 A, 1600 V SCR000150 (Toshiba)						CS5 F-600, 600 A, 500 V Fu000616
	EPJ00444X 1650A	4	SF500U27, 500 A, 1600 V SCR000229 (Toshiba)						CS5 F-800, 800 A, 500 V Fu000687

Note) Fuse maker: Fuji Electric

**Table 12-2 Spare Parts and Minimum Insurance Quantity for One VS-520B (CDMR-D5, Reversing Drive)**

Thyr. Conv. Unit		Thyristors (Maker)		Thyristor Fuses		Cont. Ckt. Fuses		Surge Absorb Fuses	
Code Rating	Type, Rating Code	Qty	Type, Rating Code	Qty	Type Rating Code	Qty	Type Rating Code	Qty	
Rated Voltage 230 V	EPJ00432X 80A	4	SF100L27, 100 A, 800 V SCR000145 (Toshiba)	4	AfoC 30/3, 3 A, 100 lA Fu000329	2	AfoC 30/30, 30 A, 100 lA Fu000334	3	
	EPJ00433X 200A		CS5 F-200, 200 A, 500 V Fu000609						
	EPJ00435X 300A	SF250L27, 250 A, 800 V SCR000147 (Toshiba)	CS5 F-350, 350 A, 500 V Fu000612						
	EPJ00437X 500A	SF400L27, 400 A, 800 V SCR000149 (Toshiba)	CS5 F-450, 450 A, 500 V Fu000614						
Rated Voltage 460 V	EPJ00447X 80A	4	SF100U27, 100 A, 1600 V SCR000146 (Toshiba)	4	AfoC 30/5, 5 A, 100 lA Fu000330	2	AfoC 30/30, 30 A, 100 lA Fu000334	4	
	EPJ00434X 200A		CS5 F-200, 200 A, 500 V Fu000609						
	EPJ00436X 300A	SF250U27, 250 A, 1600 V SCR000148 (Toshiba)	CS5 F-350, 350 A, 500 V Fu000612						
	EPJ00438X 500A	4	SF400U27, 400 A, 1600 V SCR000150 (Toshiba)						CS5 F-450, 450 A, 500 V Fu000614
	EPJ00439X 800A		CS5 F-600, 600 A, 500 V Fu000616						
	EPJ00440X 900A	4	SF500U27, 500 A, 1600 V SCR000229 (Toshiba)						CS5 F-800, 800 A, 500 V Fu000687
	EPJ00441X 1500A	8	SF400U27, 400 A, 1600 V SCR000150 (Toshiba)						CS5 F-600, 600 A, 500 V Fu000616
	EPJ00445X 1650A	8	SF500U27, 500 A, 1600 V SCR000229 (Toshiba)						CS5 F-800, 800 A, 500 V Fu000687
	EPJ00442X 1500/800A	6	SF400U27, 400 A, 1600 V SCR000150 (Toshiba)						CS5 F-600, 600 A, 500 V Fu000616
	EPJ00443X 1650/900A	6	SF500U27, 500 A, 1600 V SCR000229 (Toshiba)						CP5 F-800, 800 A, 500 V Fu000687

Note) Fuse maker: Fuji Electric

# DIAGRAMS

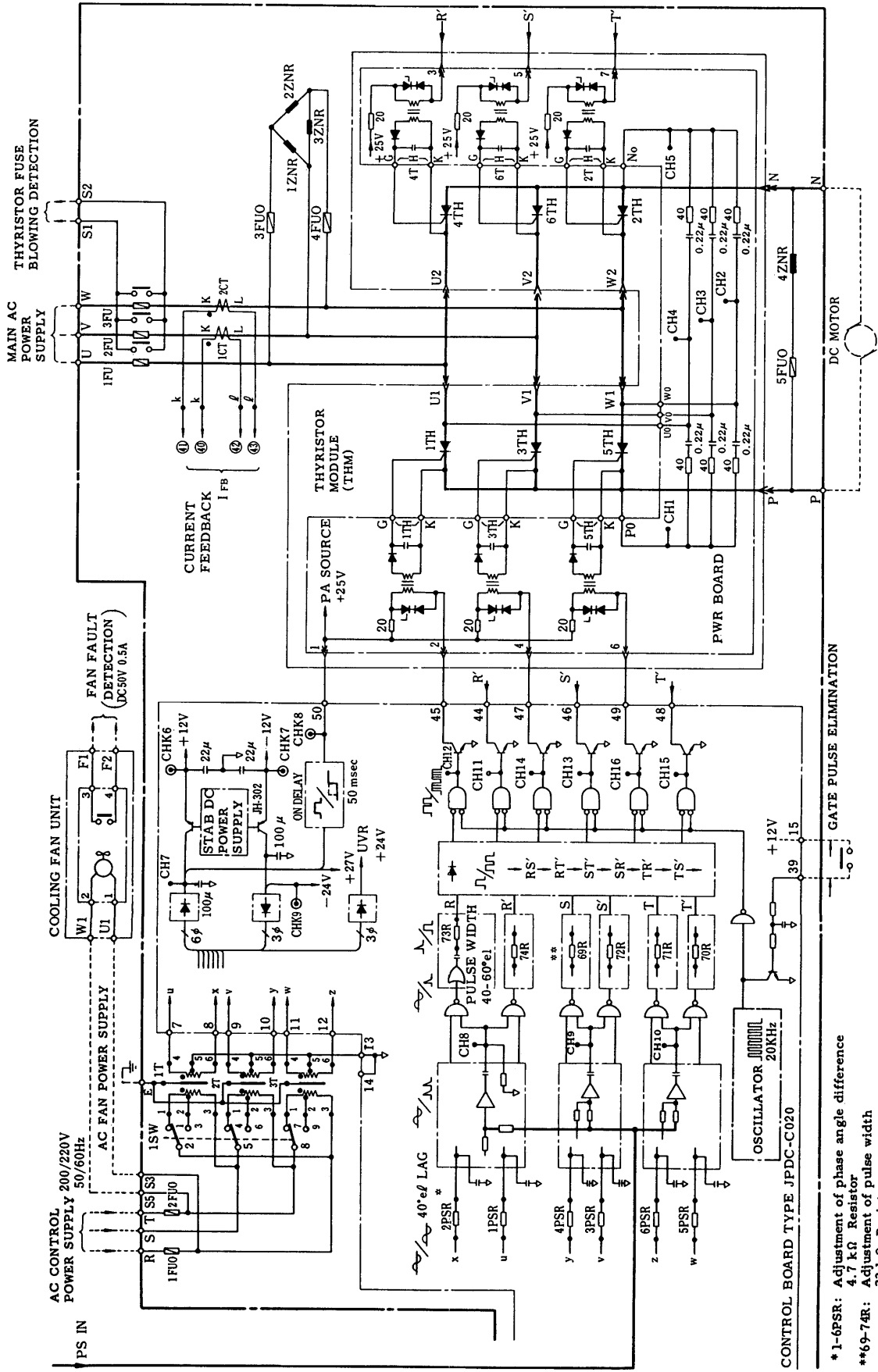

Fig. 30 Control Circuits Elementary Diagram Type CDMR-L5 Non-Reversing Drive  
230/460 V 80-500 A

\* 1-6PSR: Adjustment of phase angle difference  
4.7 kΩ Resistor  
\*\*69-74R: Adjustment of pulse width  
22 kΩ Resistor

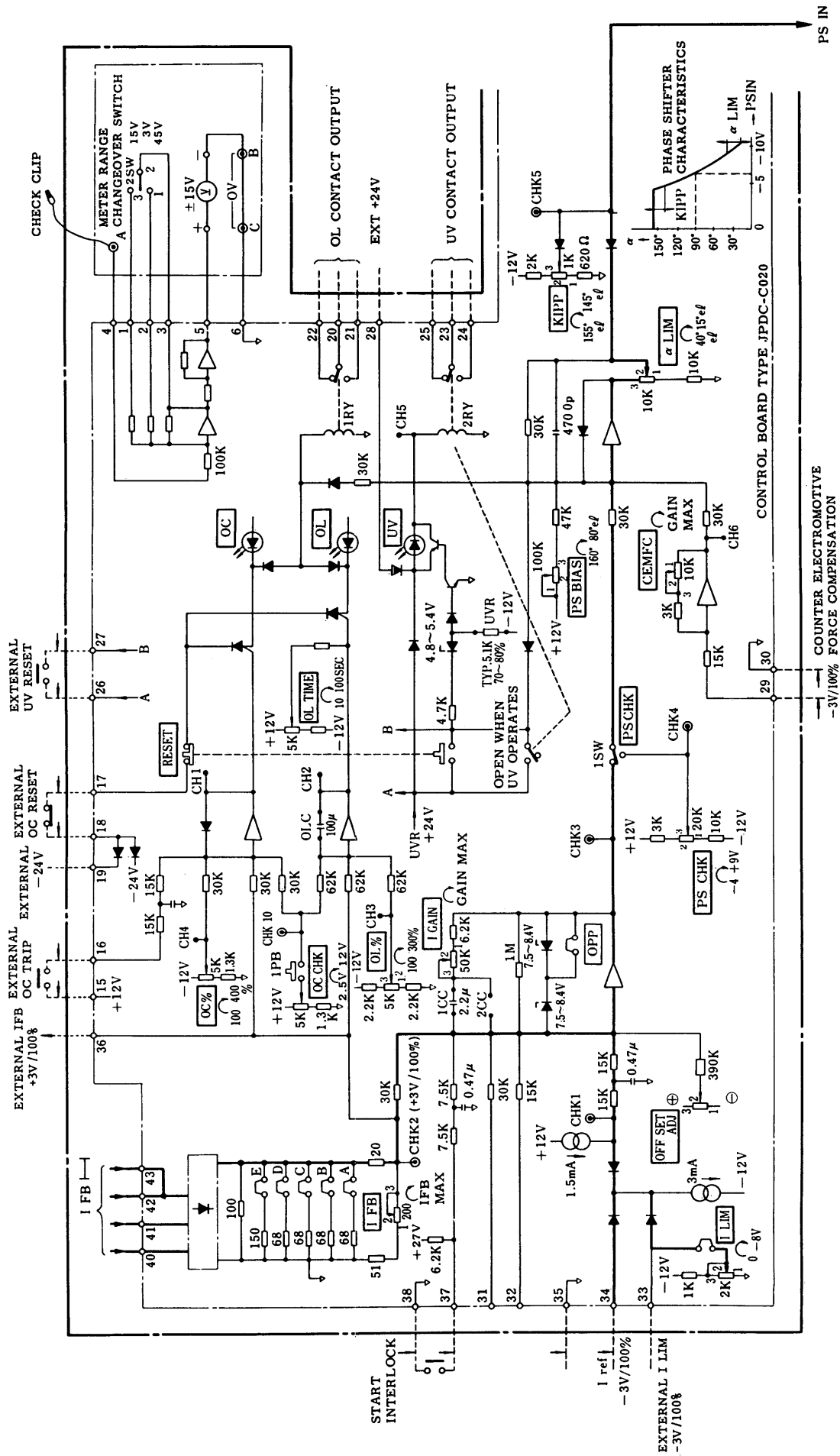

Fig. 31 Control Circuits Elementary Diagram Type CDMR-L5 Non-Reversing Drives 230/460 V 200-500 A

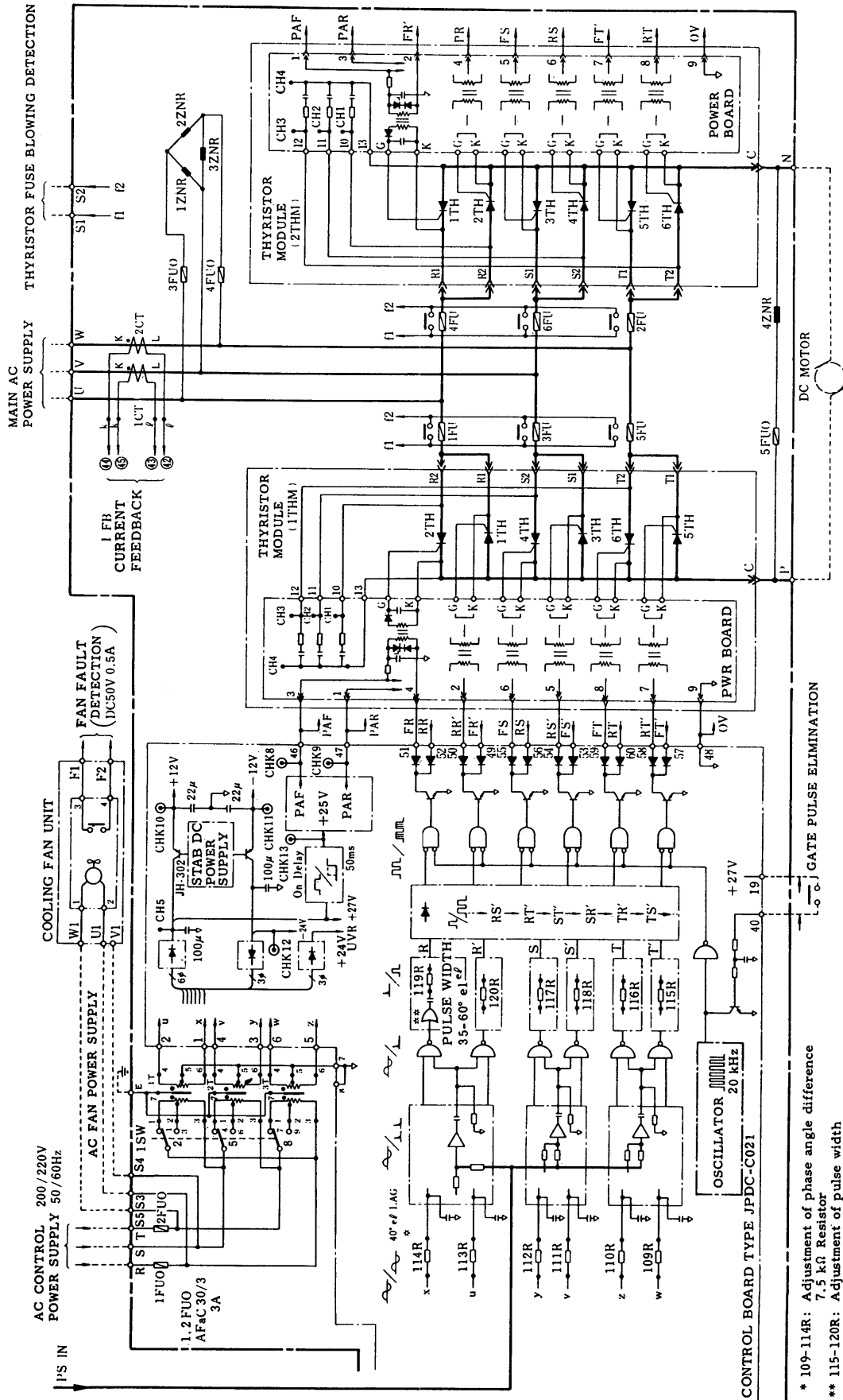

Fig. 32 Control Circuits Elementary Diagram Type CDMR-D5 Reversing Drives  
230/460 V 80-500 A

\* 109-114R: Adjustment of phase angle difference  
7.5 kΩ Resistor  
\*\* 115-120R: Adjustment of pulse width  
22 kΩ Resistor

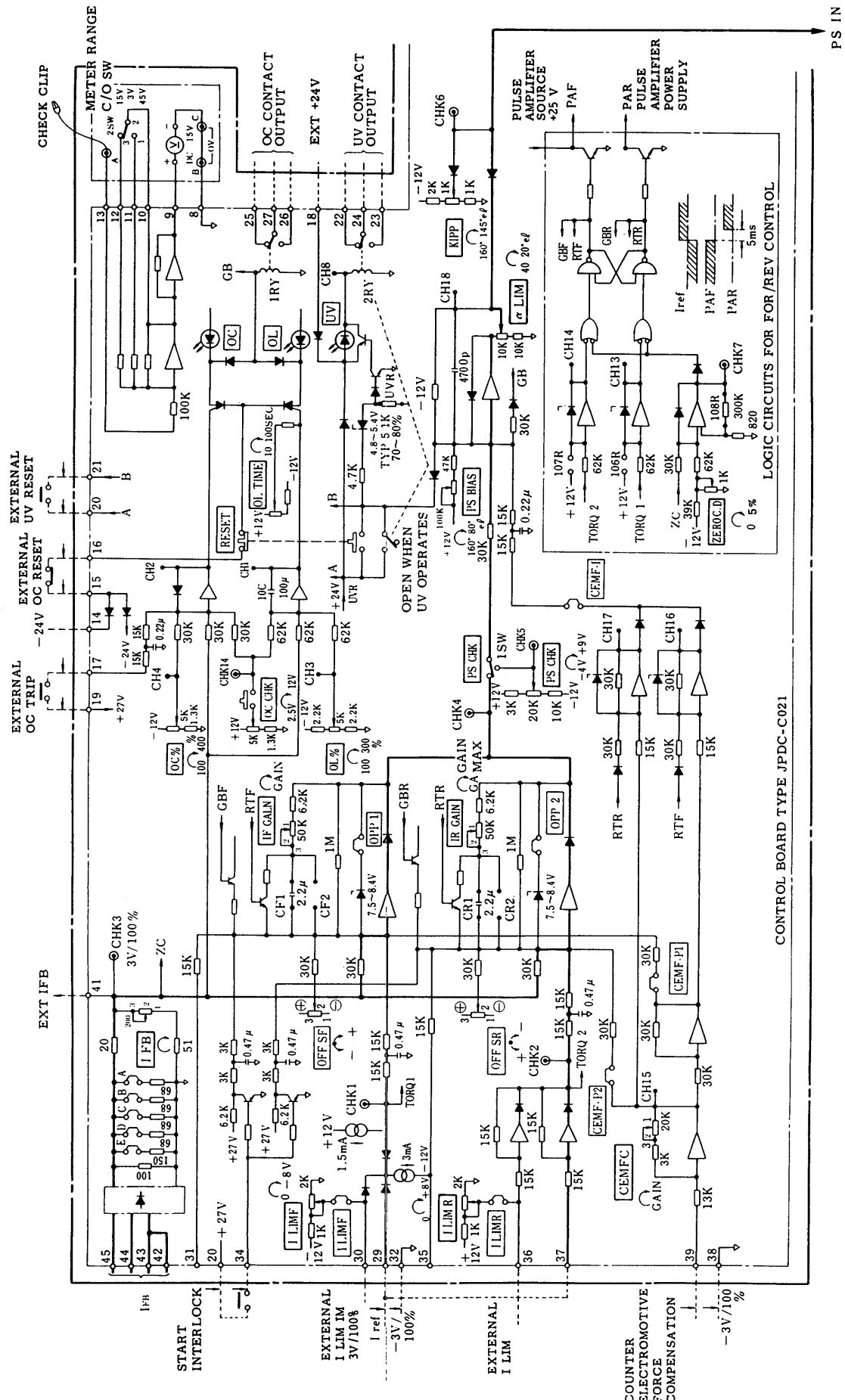

Fig. 33 Control Circuits Elementary Diagram Type CDMR-D5 Reversing Drives  
230/460 V 80-500 A

# APPENDIX

## RATED CURRENT SELECTION FOR STANDARD

Table 13 Current Selection

Ambient temperature: -10 to 45°C

Power Supply	Nominal Rated Voltage (V)		Rated Current* (A)				
	Nominal Rated Current (A)		Ao	A	Bo	B, C	D
3-phase 170 - 255 V 50/60 Hz	230V	80A	80	80	60	55	42
	230V	200A	200	200	177	159	120
	230V	300A	300	300	285	252	192
	230V	500A	500	500	480	360	255
3-phase 340 - 510 V 50/60 Hz	460V	80A	80	80	60	55	42
	460V	200A	200	200	177	159	120
	460V	300A	300	300	285	252	192
	460V	500A	500	500	480	360	255
	460V	800A	800	800	645	555	400
	460V	900A	900	900	780	720	500
	460V	1500A	1500	1500	1190	1030	740
	460V	1650A	1650	1650	1440	1330	925

\* Complying with JEC-188 (JEC: Standard of Japanese Electro-technical Committee)

- Ao: 100% Continuous
- A: 100% Continuous + (150% 60sec load)
- Bo: 100% Continuous + (125% 2hr or 200% 10sec load)
- B: 100% Continuous + (125% 2hr or 200% 60sec load)
- C: 100% Continuous + (150% 2hr or 200% 60sec load)
- D: 100% Continuous + (150% 2hr or 300% 60sec load)

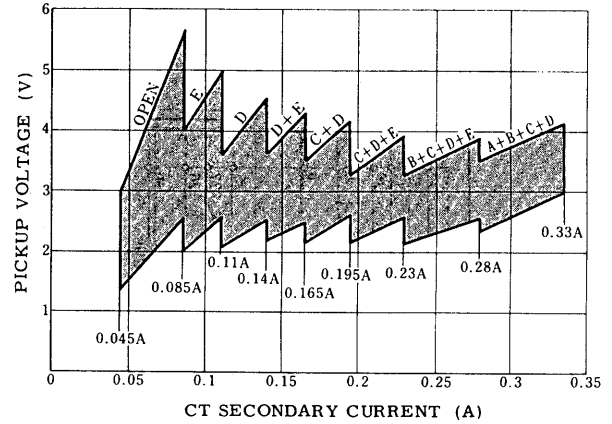
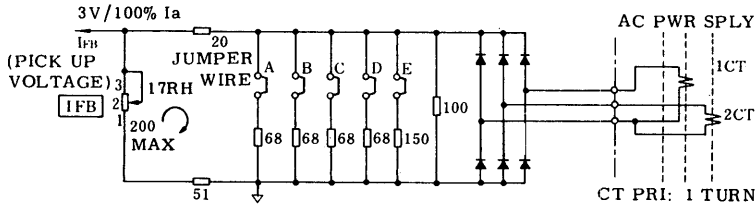

Fig. 33 Jumper Wire Selection

## CURRENT FEEDBACK CHARACTERISTICS



Ratings of VS-520B (A)	CT Primary Current (A)	CT Secondary Current (A)	Drive Method
80	80	0.2	Non-reversing / reversing
200	200	0.2	
300 - 500	500	0.2	
800, 900	1000	0.2	
1500, 1650	1500	0.2	Non-reversing
1500, 1650	1000	0.2 × 2	Reversing

Fig. 34 Current Feedback Circuits and CT Ratings

**PARTS LIST**

**Table 14-1 Parts List for Type CDMR-L5**

Thyr. Conv. Unit (Code, rating)	Fuses(2)			Surge(3) Absorb	Thyristor Module			Cont. Bd. (Code)	Fan Unit (Code)	
	Thyr. Fuses	Qty	Cont. Ckt. Fuses		Surge Absorb Fuse	Type, Rating Code	Thyristors (Type, rating)			Pwr Bd. (Type, code)
Rated Voltage 230 V	EPJ00422X 80A	3	AfoC 30/3, 3 A, 100kA	3 Pcs	ERZA32E1441 200 V Class 4 Pcs	NPSB-X, 230V, 200A ETJ00089X 1 Pcs	SF100L27 (Maker Toshiba) 800 V, 100 A 6 Pcs	JPDC-P021 ETX00117X 1 Pcs	EUX00104X	
	EPJ00423X 200A									CS5F-200 200A, 500V
	EPJ00425X 300A									CS5F-350 350A, 500V
Rated Voltage 460 V	EPJ00427X 500A	6	AfoC 30/30, 30 A, 100kA	3 Pcs	ERZA32E1881 400 V Class 4 Pcs	NPSB-X, 230V, 500A ETJ00093X 1 Pcs	SF400L27 (Maker Toshiba) 800 V, 400 A 6 Pcs	JPDC-P022 ETX00119X 1 Pcs	EUX00104X	
	EPJ00446X 80A									CS5F-200 200A, 500V
	EPJ00424X 200A									CS5F-350 350A, 500V
	EPJ00426X 300A									CS5F-500 500A, 500V
	EPJ00428X 500A									CS5F-500 500A, 500V
	EPJ00429X 800A									CS5F-600 600A, 500V
Rated Voltage 1500 V	EPJ00430X 900A	12	AfoC 30/5, 5 A	2 Pcs	ERZA32E1881 400 V Class 5 Pcs	NPSB-X, 460V, 800A ETJ00095X 6 Pcs	SF400U27 (Maker Toshiba) 1600V, 400 A 6 Pcs	JPDC-P023 ETX00119X 6 Pcs	EUX00108X	
	EPJ00431X 1500A									CS5F-600 600A, 500V
EPJ00444X 1650A	CS5F-800 800A, 500V					NPSB-X, 460V, 900A ETJ00096X 6 Pcs	SF500U27 (Maker Toshiba) 1600V, 500A	JPDC-P030 ETX00128X 6 Pcs	(1) EUX00102X	

Note) 1 JPDC-C020 (ETC00330X) 1 Pcs  
JPDC-C022 (ETC00337X) 1 Pcs  
2 Fuse Maker: Fuji Electric  
3 Surge Absorb. Maker: Matsushita Electric

**Table 14-2 Parts List for Type CDMR-D5**

Thyr. Conv. Unit (Code, rating)	Fuses(2)			Surge(3) Absorb	Thyristor Module			Cont. Bd.	Fan Unit (Code)	
	Thyr. Fuses	Qty	Cont. Ckt. Fuses		Surge Absorb. Fuses	Type, Rating Code	Thyristors (Type, rating)			Pwr Bd. (Type, code)
Rated Voltage 230 V	EPJ00432X 80A	6	AfoC 30/3, 3 A, 100kA	3 Pcs	ERZA32E1441 200 V Class 4 Pcs	NPSB-D, 230V, 200A ETJ00098X 2 Pcs	SF100L27 (Maker Toshiba) 800V, 100A 12 Pcs	JPDC-P026 ETX00122X 2 Pcs	EUX00107X	
	EPJ00433X 200A									CS5F-200 200A, 500V
	EPJ00435X 300A									CS5F-350 350A, 500V
Rated Voltage 460 V	EPJ00437X 500A	12	AfoC 30/5, 5 A	2 Pcs	ERZA32E1881 400 V Class 4 Pcs	NPSB-D, 230V, 500A ETJ00102X 2 Pcs	SF400L27 (Maker Toshiba) 800V, 400A 12 Pcs	JPDC-P027 ETX00123X 2 Pcs	EUX00107X	
	EPJ00447X 80A									CS5F-450 450A, 500V
	EPJ00434X 200A									CS5F-200 200A, 500V
	EPJ00436X 300A									CS5F-350 350A, 500V
	EPJ00438X 500A									CS5F-450 450A, 500V
	EPJ00439X 800A									CS5F-600 600A, 500V
Rated Voltage 1500 V	EPJ00440X 900A	12	AfoC 30/30, 30 A	4 Pcs	ERZA32E1881 400 V Class 5 Pcs	NPSB-D, 460V, 800A ETJ00104X 12 Pcs	SF400U27 (Maker Toshiba) 1600V, 400A 24 Pcs	JPDC-P028 ETX00124X 6 Pcs	EUX00108X	
	EPJ00441X 1500A									CS5F-600 600A, 500V
EPJ00445X 1650A	CS5F-800 800A, 500V					NPSB-D, 460V, 900A ETJ00105X 12 Pcs	SF500U27 (Maker Toshiba) 1600V, 500A	JPDC-P028 ETX00124X 12 Pcs	(1) EUX00102X	

Note) 1 JPDC-C021 (ETC00331X) 1 Pcs  
JPDC-C022 (ETC00337X) 1 Pcs  
2 Fuse Maker: Fuji Electric  
3 Surge Absorb. Maker: Matsushita Electric

# Varispeed-520B

# INSTRUCTIONS

## **TOKYO OFFICE**

New Pier Takeshiba South Tower, 1-16-1, Kaigan, Minatoku, Tokyo 105-0022 Japan  
Phone 81-3-5402-4511 Fax 81-3-5402-4580

## **YASKAWA ELECTRIC AMERICA, INC.**

### **Chicago-Corporate Headquarters**

2942 MacArthur Blvd. Northbrook, IL 60062-2028, U.S.A.

Phone 1-847-291-2340 Fax 1-847-498-2430

### **Chicago-Technical Center**

3160 MacArthur Blvd. Northbrook, IL 60062-1917, U.S.A.

Phone 1-847-291-0411 Fax 1-847-291-1018

## **MOTOMAN INC. HEADQUARTERS**

805 Liberty Lane West Carrollton, OH 45449, U.S.A.

Phone 1-937-847-6200 Fax 1-937-847-6277

## **YASKAWA ELETRICO DO BRASIL COMERCIO LTDA.**

Avenida Fagundes Filho, 620 Bairro Saude-Sao Paulo-SP, Brazil CEP: 04304-000

Phone 55-11-5071-2552 Fax 55-11-5581-8795

## **YASKAWA ELECTRIC EUROPE GmbH**

Am Kronberger Hang 2, 65824 Schwalbach, Germany

Phone 49-6196-569-300 Fax 49-6196-888-301

## **Motoman Robotics AB**

Box 504 S38525 Torsås, Sweden

Phone 46-486-48800 Fax 46-486-41410

## **Motoman Robotec GmbH**

Kammerfeldstraße 1, 85391 Allershausen, Germany

Phone 49-8166-900 Fax 49-8166-9039

## **YASKAWA ELECTRIC UK LTD.**

1 Hunt Hill Orchardton Woods Cumbernauld, G68 9LF, United Kingdom

Phone 44-1236-735000 Fax 44-1236-458182

## **YASKAWA ELECTRIC KOREA CORPORATION**

Paik Nam Bldg. 901 188-3, 1-Ga Euljiro, Joong-Gu Seoul, Korea

Phone 82-2-776-7844 Fax 82-2-753-2639

## **YASKAWA ELECTRIC (SINGAPORE) PTE. LTD.**

151 Lorong Chuan, #04-01, New Tech Park Singapore 556741, Singapore

Phone 65-282-3003 Fax 65-289-3003

## **YATEC ENGINEERING CORPORATION**

Shen Hsiang Tang Sung Chiang Building 10F 146 Sung Chiang Road, Taipei, Taiwan

Phone 886-2-2563-0010 Fax 886-2-2567-4677

## **BEIJING OFFICE**

Room No. 301 Office Building of Beijing International Club, 21

Jianguomenwai Avenue, Beijing 100020, China

Phone 86-10-6532-1850 Fax 86-10-6532-1851

## **SHANGHAI OFFICE**

27 Hui He Road Shanghai 200437 China

Phone 86-21-6553-6600 Fax 86-21-6531-4242

## **YASKAWA JASON (HK) COMPANY LIMITED**

Rm. 2909-10, Hong Kong Plaza, 186-191 Connaught Road West, Hong Kong

Phone 852-2803-2385 Fax 852-2547-5773

## **TAIPEI OFFICE**

Shen Hsiang Tang Sung Chiang Building 10F 146 Sung Chiang Road, Taipei, Taiwan

Phone 886-2-2563-0010 Fax 886-2-2567-4677

## **SHANGHAI YASKAWA-TONGJI M & E CO., LTD.**

27 Hui He Road Shanghai China 200437

Phone 86-21-6531-4242 Fax 86-21-6553-6060

## **BEIJING YASKAWA BEIKE AUTOMATION ENGINEERING CO., LTD.**

30 Xue Yuan Road, Haidian, Beijing P.R. China Post Code: 100083

Phone 86-10-6233-2782 Fax 86-10-6232-1536

## **SHOUGANG MOTOMAN ROBOT CO., LTD.**

7, Yongchang-North Street, Beijing Economic Technological Investment & Development Area,

Beijing 100076, P.R. China

Phone 86-10-6788-0551 Fax 86-10-6788-2878



YASKAWA ELECTRIC CORPORATION

YASKAWA

Specifications are subject to change without notice  
for ongoing product modifications and improvements.